

Professional Digital Two-Way Radio System

MOTOTRBO™ Repeater

Basic Service Manual

DR 3000 Repeater





MOTOROLA

DR 3000
UHF Range 1
MOTOTRBO™ Repeater
Basic Service Manual

Foreword

This manual covers all models of the MOTOTRBO Repeater, unless otherwise specified. It includes all the information necessary to maintain peak product performance and maximum working time, using levels 1 and 2 maintenance procedures. This level of service goes down to the board replacement level and is typical of some local service centers, Motorola Authorized Dealers, self-maintained customers, and distributors.

For details on repeater operation or component-level troubleshooting, refer to the applicable manuals available separately.

Product Safety and RF Exposure Compliance

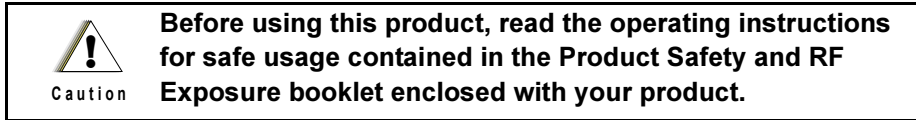

ATTENTION!

This repeater is restricted to occupational use only to satisfy ICNIRP/FCC RF energy exposure requirements. Before using this product, read the RF energy awareness information and operating instructions in the Product Safety and RF Exposure booklet enclosed with your product (Motorola Publication part number 6866537D37) to ensure compliance with RF energy exposure limits.

For a list of Motorola-approved antennas, and other accessories, visit the following web site which lists approved accessories: <http://www.motorola.com/governmentandenterprise>

Computer Software Copyrights

The Motorola products described in this manual may include copyrighted Motorola computer programs stored in semiconductor memories or other media. Laws in the United States and other countries preserve for Motorola certain exclusive rights for copyrighted computer programs, including, but not limited to, the exclusive right to copy or reproduce in any form the copyrighted computer program. Accordingly, any copyrighted Motorola computer programs contained in the Motorola products described in this manual may not be copied, reproduced, modified, reverse-engineered, or distributed in any manner without the express written permission of Motorola. Furthermore, the purchase of Motorola products shall not be deemed to grant either directly or by implication, estoppel, or otherwise, any license under the copyrights, patents or patent applications of Motorola, except for the normal non-exclusive license to use that arises by operation of law in the sale of a product.

Document Copyrights

No duplication or distribution of this document or any portion thereof shall take place without the express written permission of Motorola. No part of this manual may be reproduced, distributed, or transmitted in any form or by any means, electronic or mechanical, for any purpose without the express written permission of Motorola.

Disclaimer

The information in this document is carefully examined, and is believed to be entirely reliable. However, no responsibility is assumed for inaccuracies. Furthermore, Motorola reserves the right to make changes to any products herein to improve readability, function, or design. Motorola does not assume any liability arising out of the applications or use of any product or circuit described herein; nor does it cover any license under its patent rights nor the rights of others.

Trademarks

MOTOROLA and the Stylized M logo are registered in the U.S. Patent & Trademark Office. All other product or service names are the property of their respective owners.

© 2007 by Motorola, Inc.
All rights reserved.

Document History

The following major changes have been implemented in this manual since the previous edition:

Edition	Description	Date
6866576D03-A	Initial Release	Feb. 2007

Notes

Table of Contents

Foreword	ii
Product Safety and RF Exposure Compliance	ii
Computer Software Copyrights	ii
Document Copyrights.....	ii
Disclaimer.....	ii
Trademarks	ii
 Document History	 iii
 Chapter 1 Introduction	 1-1
1.1 Notations Used in This Manual.....	1-1
1.2 Repeater Description	1-1
1.3 MOTOTRBO Repeater Model Numbering Scheme.....	1-2
1.4 UHF1 High Power MOTOTRBO Repeater (403-470 MHz) Model Chart.....	1-3
1.5 Specifications.....	1-4
 Chapter 2 Test Equipment and Service Aids	 2-1
2.1 Recommended Test Equipment	2-1
2.2 Service Aids.....	2-2
2.3 Programming Cables	2-2
 Chapter 3 Transceiver Performance Testing	 3-1
3.1 General	3-1
3.2 Setup	3-1
 Chapter 4 Repeater Tuning and Programming	 4-1
4.1 Introduction	4-1
4.2 Customer Programming Software Setup	4-1
4.3 Repeater Tuning Setup.....	4-2
 Chapter 5 Disassembly/Reassembly Procedures	 5-1
5.1 Introduction	5-1
5.2 Preventive Maintenance	5-1
5.2.1 Inspection	5-1
5.2.2 Cleaning Procedures	5-1
5.3 Safe Handling of CMOS and LDMOS Devices	5-2
5.4 Repair Procedures and Techniques — General	5-3
5.5 Disassembling and Reassembling the Repeater — General	5-4

5.6	Disassembly Procedures — Detailed	5-4
5.6.1	Disassembly of Cover.....	5-4
5.6.2	Disassembly of Repeater Indicator Board	5-5
5.6.3	Disassembly of Fan	5-6
5.6.4	Removing Transmit Radio	5-7
5.6.4.1	Removing Thermal Pad and Heatsink	5-8
5.6.5	Removing Receive Radio, Power Supply and Connector Board Assembly	5-8
5.6.5.1	Disassembly of Receive Radio	5-10
5.6.5.2	Disassembly of Connector Board Assembly	5-10
5.6.5.3	Disassembly of Power Supply	5-10
5.7	Transmit and Receive Radio Disassembly — Detailed	5-11
5.7.1	Transceiver Board and Receiver Board Removal	5-11
5.8	Transmit and Receive Radio Reassembly — Detailed	5-14
5.8.1	Transceiver Board and Receiver Board Reassembly	5-15
5.8.2	Thermal Pad Replacement Procedure	5-19
5.8.3	Reassembly of Receive Radio, Power Supply and Connector Board Assembly.....	5-21
5.8.3.1	Reassembly of Power Supply	5-21
5.8.3.2	Reassembly of Receive Radio.....	5-21
5.8.3.3	Reassembly of Connector Board Assembly	5-21
5.8.3.4	Reassembly of the Receive Bracket Assembly to the Enclosure	5-21
5.8.4	Reassembly of Transmit Radio.....	5-22
5.8.4.1	Replacing the Thermal Pad and Heatsink	5-22
5.8.4.2	Reassembly of the Transmit Bracket Assembly to the Enclosure	5-22
5.8.5	Reassembly of Fan.....	5-23
5.8.6	Reassembly of Repeater Indicator Board.....	5-23
5.8.7	Reassembly of Cover	5-23
5.9	Repeater Exploded Mechanical Views and Parts Lists.....	5-24
5.10	Torque Chart.....	5-27
 Chapter 6 Basic Troubleshooting		6-1
6.1	Introduction	6-1
6.1.1	High Power RF Precaution	6-1
6.2	Replacement Service Kit Procedures	6-1
6.3	LED Indicator Descriptions	6-2
 Appendix A EMEA Regional Warranty, Service and Support.....		A-1
A.1	Warranty and Service Support.....	A-1
A.2	European Radio Support Centre (ERSC)	A-2
A.3	Piece Parts.....	A-2
A.4	Technical Support	A-3
A.5	Further Assistance From Motorola.....	A-3
 Glossary		Glossary-1

List of Figures

Figure 1-1.	Repeater Model Numbering Scheme.....	1-2
Figure 2-1.	Mobile & Repeater Rear Programming Cable PMKN4010_.....	2-2
Figure 2-2.	Mobile & Repeater Rear Programming, Testing & Alignment Cable PMKN4016_.....	2-3
Figure 4-1.	Customer Programming Software Setup from Rear Accessory Connector	4-1
Figure 4-2.	Repeater Tuning Equipment Setup.....	4-2
Figure 5-1.	Removing Top Cover of Repeater Enclosure.....	5-4
Figure 5-2.	Disconnecting Ethernet Cable and Flex Cable	5-5
Figure 5-3.	Repeater Indicator Board Disassembly.....	5-6
Figure 5-4.	Fan Orientation.....	5-6
Figure 5-5.	Tx Radio Disassembly	5-7
Figure 5-6.	Receive Radio Removal.....	5-9
Figure 5-7.	Die Cast Cover Removal.....	5-11
Figure 5-8.	Accessory Connector Removal.....	5-12
Figure 5-9.	RF/DC Retention Clips Removal.....	5-12
Figure 5-10.	Transceiver Board Removal.....	5-13
Figure 5-11.	Thermal Pads and Shield Gasketing on Chassis and Die Cast Cover.....	5-14
Figure 5-12.	Transceiver Board with Thermal Pads	5-14
Figure 5-13.	Replacing GPS Plug	5-15
Figure 5-14.	Placing the Transceiver Board in the Chassis.....	5-15
Figure 5-15.	Inserting RF/DC Retention Clips	5-16
Figure 5-16.	Inserting Accessory Connector	5-16
Figure 5-17.	Assembling of PA Pad and O-ring.....	5-17
Figure 5-18.	Assembling Die Cast Cover onto Chassis	5-18
Figure 5-19.	Screw Sequence to Tighten Die Cast Cover.....	5-19
Figure 5-20.	Replacing Thermal Pads.....	5-19
Figure 5-21.	Aligning Driver Pad on Chassis.....	5-20
Figure 5-22.	Placing Thermal Pads on PA and Transistor Components	5-20
Figure 5-23.	Fan Orientation.....	5-23
Figure 5-24.	Repeater Assembly Exploded View	5-24
Figure 5-25.	Receive Bracket and Radio Assembly Exploded View	5-25
Figure 5-26.	Transmit Bracket and Radio Assembly Exploded View.....	5-25
Figure 5-27.	Front Panel Complete Assembly Exploded View.....	5-26

List of Tables

Table 1-1.	Frequency Ranges and Power Levels	1-1
Table 2-1.	Recommended Test Equipment	2-1
Table 2-2.	Service Aids	2-2
Table 3-1.	Initial Equipment Control Settings	3-1
Table 3-2.	Receiver Performance Checks	3-2
Table 4-1.	Repeater Software Program Kits	4-1
Table 5-1.	Lead Free Solder Wire Part Number List	5-3
Table 5-2.	Lead Free Solder Paste Part Number List	5-3
Table 5-3.	Repeater Exploded View Parts List	5-26
Table 5-4.	Torque Specifications for Nuts and Screws	5-27
Table 6-1.	LED Indicator Descriptions	6-2

Chapter 1 Introduction

1.1 Notations Used in This Manual

Throughout the text in this publication, you will notice the use of note and caution notations. These notations are used to emphasize that safety hazards exist, and due care must be taken and observed.

NOTE: An operational procedure, practice, or condition that is essential to emphasize.

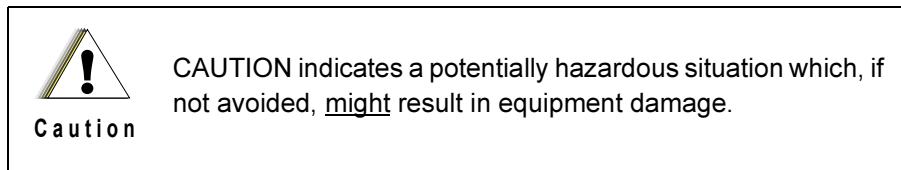

1.2 Repeater Description

The MOTOTRBO Repeater is Motorola's newest two-way digital and analog repeater designed for your organization's most demanding needs. The repeater is available in the following frequency ranges and power levels.

Table 1-1. Frequency Ranges and Power Levels

Frequency Band	Bandwidth	Power Level
UHF R1	403–470 MHz	25-40 Watts

This repeater is among the most sophisticated two-way repeaters available. It has a new robust design for users who need high performance, quality, and reliability in their daily communications. This new architecture provides the capability of supporting a multitude of legacy and advanced features resulting in a more cost-effective two-way repeater communications solution.

1.3 MOTOTRBO Repeater Model Numbering Scheme

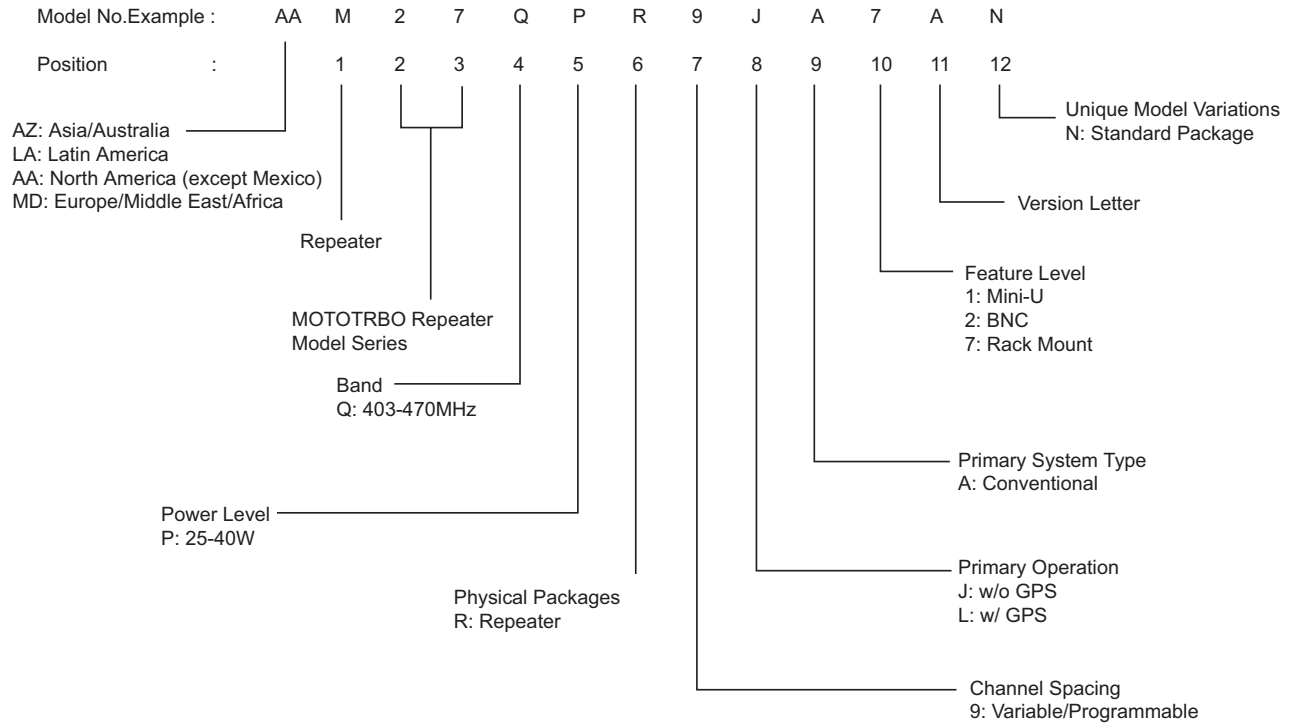

Figure 1-1. Repeater Model Numbering Scheme

1.4 UHF1 High Power MOTOTRBO Repeater (403-470 MHz) Model Chart

UHF1 403-470 MHz, 25-40W		
Model		Description
MDM27QPR9JA7AN		403-470 MHz, 25-40W, MOTOTRBO Repeater
	Item	Description
X	PMLN4815_	Connector Board Assembly
X	PMLN4814_	Repeater Indicator Board
X	PMUE2390_S	Repeater Service Kit
X	3002695D05 NNTN7373_R NNTN7374_R	Power Supply UK Power Supply US Power Supply EU
X	6866537D37	Product Safety and RF Exposure Booklet

X = Item Included

_ = the latest version kit. When ordering a kit, refer to your specific kit for the suffix number.

1.5 Specifications

General	
Specification	UHF1
Channel Capacity	1
Technical RF Output	25-40W
Frequency	403-470 MHz
Dimensions (HxWxL)	132.6 mm x 482.6 mm x 296.5 mm
Weight	14 kg
Voltage Requirements	100-240 V AC 47-63 Hz (13.6 V DC)
Current Drain: Standby Transmit	0.5 A (1 A DC typical) 1.5 A (11 A DC typical)
Operating Temperature Range	-30°C to +60°C
Max Duty Cycle	100%

Receiver	
Specification	UHF1
Frequency	403-470 MHz
Channel Spacing	12.5 kHz/25 kHz
Frequency Stability (-30°C to +60°C)	±0.5 ppm
Analog Sensitivity	0.30 µV (12 dB SINAD) 0.22 µV (typical) (12 dB SINAD) 0.40 µV (20 dB SINAD)
Digital Sensitivity	5% BER: 0.3 µV
Intermodulation	70 dB
Adjacent Channel Selectivity:	60 dB @ 12.5 kHz, 70 dB @ 25 kHz
Spurious Rejection	70 dB
Audio Distortion @ Rated Audio	3% (typical)
Hum and Noise	-40 dB @ 12.5 kHz -45 dB @ 25 kHz
Audio Response	+1, -3 dB
Conducted Spurious Emission	-57 dBm

Transmitter	
Specification	UHF1
Frequency	403-470 MHz
Channel Spacing	12.5 kHz/25 kHz
Frequency Stability (-30°C to +60°C)	±0.5 ppm
Power Output	25-40 W
Modulation Limiting	±2.5 kHz @ 12.5 kHz ±5.0 kHz @ 25 kHz
FM Hum and Noise	-40 dB @ 12.5 kHz -45 dB @ 25 kHz
Conducted/Radiated Emission	-36 dBm < 1 GHz -30 dBm > 1 GHz
Adjacent Channel Power	60 dB @ 12.5 kHz 70 dB @ 25 kHz
Audio Response	+1, -3 dB
Audio Distortion	3%
Digital Vocoder Type	AMBE++
Digital Protocol	ETSI-TS102 361-1

Conforms to:

ETSI TS 102 361 (Parts 1, 2 & 3) - ETSI DMR Standard

1999/5/EC (R&TTE - Radio and Telecommunications Terminal Equipment)

2002/95/EC (RoHS - Banned Substances)

2002/96/EC (WEEE - Waste Electrical and Electronic Equipment)

94/62/EC (Packaging and Packaging Waste)

Radio meets applicable regulatory requirements.

Specifications subject to change without notice. All specifications shown are typical.

Notes

Chapter 2 Test Equipment and Service Aids

2.1 Recommended Test Equipment

The list of equipment contained in Table 2-1 includes most of the standard test equipment required for servicing Motorola repeaters.

Table 2-1. Recommended Test Equipment

Equipment	Characteristic	Example	Application
Service Monitor	Can be used as a substitute for items marked with an asterisk (*)	Aeroflex 2975 (www.aeroflex.com), Motorola R2670, or equivalent	Frequency/deviation meter and signal generator for wide-range troubleshooting and alignment
Digital RMS Multimeter*	100 μ V to 300 V 5 Hz to 1 MHz 10 Meg Ohm Impedance	Fluke 179 or equivalent (www.fluke.com)	AC/DC voltage and current measurements. Audio voltage measurements
RF Signal Generator*	100 MHz to 1 GHz -130 dBm to +10 dBm FM Modulation 0 kHz to 10 kHz	Agilent N5181A (www.agilent.com), Ramsey RSG1000B (www.ramseyelectronics.com), or equivalent	Receiver measurements
Oscilloscope*	2 Channel 50 MHz Bandwidth 5 mV/div to 20 V/div	Leader LS8050 (www.leaderusa.com), Tektronix TDS1001b (www.tektronix.com), or equivalent	Waveform measurements
Power Meter and Sensor*	5% Accuracy 100 MHz to 500 MHz 50 Watts	Bird 43 Thruline Watt Meter (www.bird-electronic.com) or equivalent	Transmitter power output measurements
RF Millivolt Meter	100 mV to 3 V RF 10 kHz to 1 GHz	Boonton 92EA (www.boonton.com) or equivalent	RF level measurements

2.2 Service Aids

Table 2-2 lists the service aids recommended for working on the repeater. While all of these items are available from Motorola, most are standard workshop equipment items, and any equivalent item capable of the same performance may be substituted for the item listed.

Table 2-2. Service Aids

Motorola Part Number	Description	Application
RLN4460_	Test Set	Enables connection to audio/accessory jack. Allows switching for radio testing.
GMVN5141_	Customer Programming Software on CD-ROM	Allows servicer to program repeater parameters, tune and troubleshoot repeaters.
PMKN4016_	Mobile & Repeater Rear Programming, Testing & Alignment Cable	Connects the radio's rear connector to a USB port for radio programming, data applications, testing and alignment.
PMKN4010_	Mobile & Repeater Rear Programming Cable	Connects the radio's rear connector to a USB port for radio programming and data applications.

2.3 Programming Cables

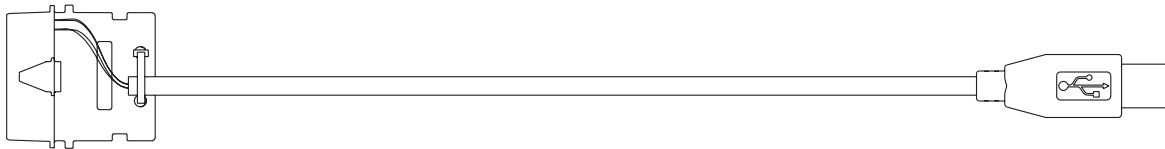

Figure 2-1. Mobile & Repeater Rear Programming Cable PMKN4010_

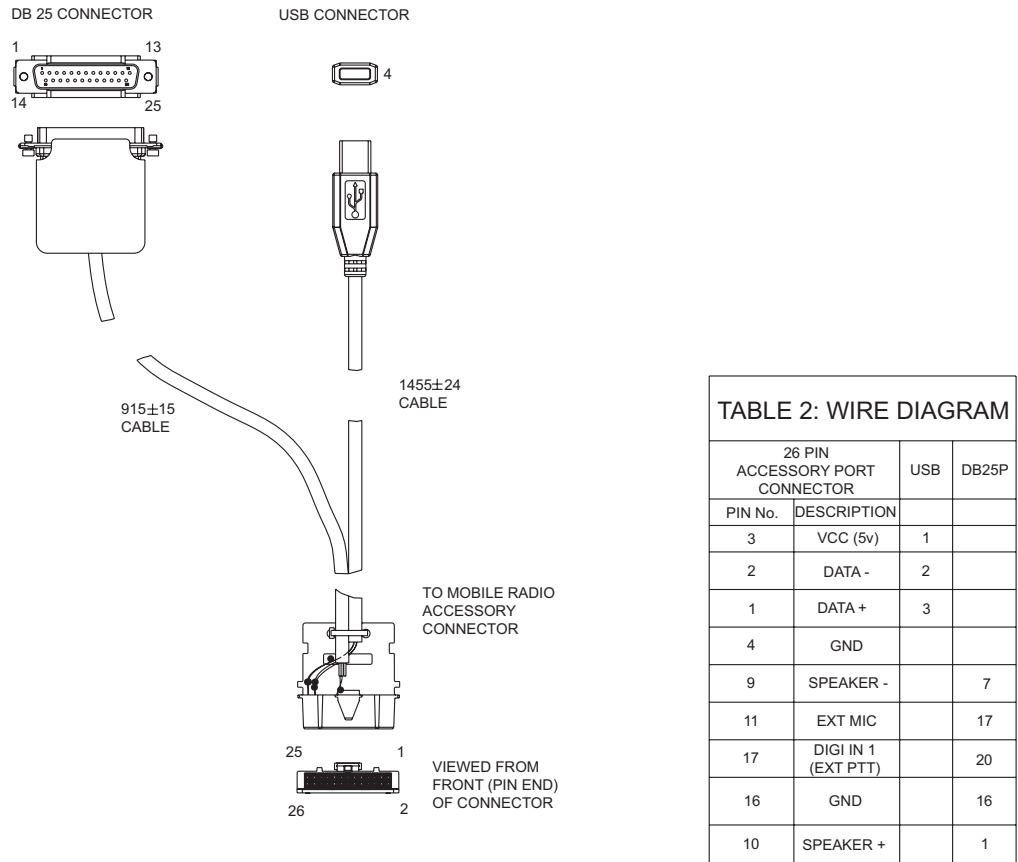

Figure 2-2. Mobile & Repeater Rear Programming, Testing & Alignment Cable PMKN4016_

Notes

Chapter 3 Transceiver Performance Testing

3.1 General

The MOTOTRBO Repeater meets published specifications through their manufacturing process by utilizing high-accuracy laboratory-quality test equipment. The recommended field service equipment approaches the accuracy of the manufacturing equipment with few exceptions. This accuracy must be maintained in compliance with the manufacturer's recommended calibration schedule.

NOTE: Although these radios function in digital and analog modes, all testing is done in analog mode.

3.2 Setup

Supply voltage is 120/240 VAC. The equipment required for alignment procedures is connected as shown in the Repeater Tuning Equipment Setup Diagram, Figure 4-2.

Initial equipment control settings should be as indicated in Table 3-1. Table 3-2 lists Receiver Performance Checks information.

Table 3-1. Initial Equipment Control Settings

Service Monitor	Test Set
Monitor Mode: Power Monitor	Speaker set: A
RF Attenuation: -70	Speaker/load: Speaker
AM, CW, FM: FM	PTT: OFF
Oscilloscope Source: Mod Oscilloscope Horizontal: 10 mSec/Div Oscilloscope Vertical: 2.5 kHz/Div Oscilloscope Trigger: Auto Monitor Image: Hi Monitor Bandwidth: Narrow Monitor Squelch: middle setting Monitor Vol: 1/4 setting	

Table 3-2. Receiver Performance Checks

Test Name	Communications Analyzer	Radio	Test Set	Comment
Rated Audio	Mode: GEN Output level: 1.0 mV RF 4th channel test frequency* Mod: 1kHz tone at 3 kHz deviation Monitor: DVM: AC Volts	Use tuner tool to program repeater to an appropriate test frequency with carrier squelch.	PTT to OFF (center), meter selector to Audio PA	Set volume to 7.75 Vrms via tuner tool.
Distortion	As above, except to distortion	As above	As above	Distortion <5.0%
Sensitivity (SINAD)	As above, except SINAD, lower the RF level for 12 dB SINAD.	As above	PTT to OFF (center)	RF input to be <0.3 μ V
Noise Squelch Threshold (only radios with conventional system need to be tested)	RF level set to 1mV RF	As above	PTT to OFF (center), meter selection to Audio PA, speaker/ load to speaker	Set volume to 7.75 Vrms via tuner tool.
	As above, except change frequency to a conventional system. Raise RF level from zero until radio unsquelches.	out of TEST MODE; select a conventional system	As above	Unsquelch to occur at <0.25 μ V. Preferred SINAD = 9 - 10 dB

Chapter 4 Repeater Tuning and Programming

4.1 Introduction

This chapter provides an overview of the MOTOTRBO Customer Programming Software (CPS), as well as the Tuner application, which are all designed for use on Windows 2000/XP operating system. These programs are available in one kit as listed in the Table 4-1. An Installation Guide is also included with the kit.

NOTE: Refer to the appropriate program on-line help files for the programming procedures.

Table 4-1. Repeater Software Program Kits

Description	Kit Number
MOTOTRBO CPS, Tuner and AirTracer Applications CD	GMVN5141_

4.2 Customer Programming Software Setup

The Customer Programming Software setup, shown in Figure 4-1 is used to program the repeater.

NOTE: Refer to the appropriate program on-line help files for the programming procedures.

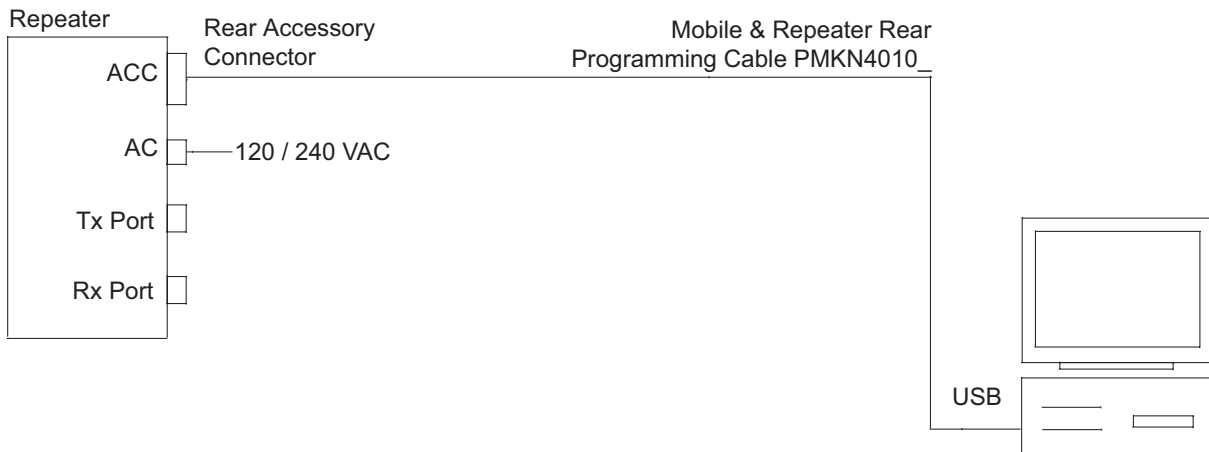

Figure 4-1. Customer Programming Software Setup from Rear Accessory Connector

4.3 Repeater Tuning Setup

A personal computer (PC), Windows 2000/XP and a tuner program (which is available as part of the MOTOTRBO CPS kit) are required to tune the repeater. To perform the tuning procedures, the repeater must be connected to the PC and test equipment setup as shown in Figure 4-2.

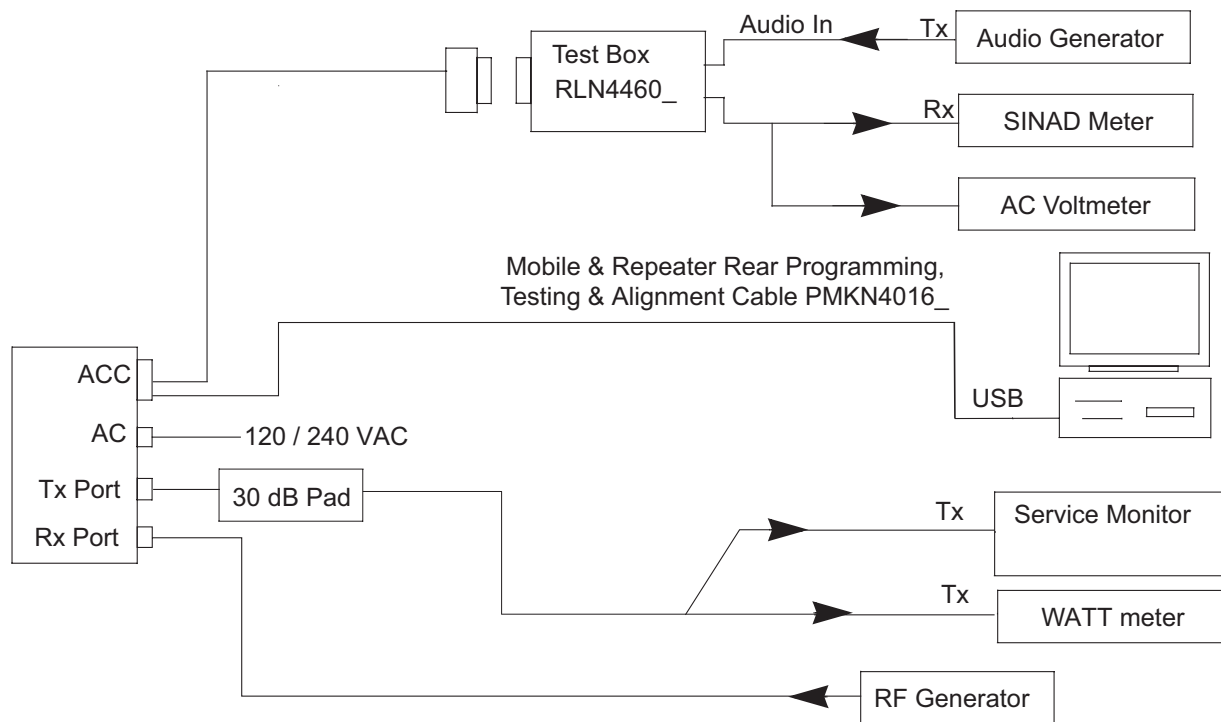

Figure 4-2. Repeater Tuning Equipment Setup

Chapter 5 Disassembly/Reassembly Procedures

5.1 Introduction

This chapter provides details about the following:

- Preventive maintenance (inspection and cleaning).
- Safe handling of CMOS and LDMOS devices.
- Disassembly and reassembly of the repeater.
- Disassembly and reassembly of the Transmit and Receive radios.
- Repair procedures and techniques.

5.2 Preventive Maintenance

Periodic visual inspection and cleaning is recommended.

5.2.1 Inspection

Check that the external surfaces of the repeater are clean, and that all external controls and switches are functional. It is not recommended to inspect the interior electronic circuitry.

5.2.2 Cleaning Procedures

The following procedures describe the recommended cleaning agents and the methods to be used when cleaning the external and internal surfaces of the repeater. External surfaces include the top cover and repeater enclosure.

Periodically clean smudges and grime from exterior enclosure. Use a soft, non-abrasive cloth moistened in a mild soap and water solution. Rinse the surface using a second cloth moistened in clean water, and clean any dirt or debris from the fan grill and louvers on the front side.

NOTE: Internal surfaces should be cleaned only when the repeater is disassembled for service or repair.

The only recommended agent for cleaning the external repeater surfaces is a 0.5% solution of a mild dishwashing detergent in water. The only factory recommended liquid for cleaning the printed circuit boards and their components is isopropyl alcohol (70% by volume).

Cleaning Internal Circuit Boards and Components

Isopropyl alcohol (70%) may be applied with a stiff, non-metallic, short-bristled brush to dislodge embedded or caked materials located in hard-to-reach areas. The brush stroke should direct the dislodged material out and away from the inside of the repeater. Make sure that controls or tunable components are not soaked with alcohol. Do not use high-pressure air to hasten the drying process since this could cause the liquid to collect in unwanted places. Once the cleaning process is complete, use a soft, absorbent, lintless cloth to dry the area. Do not brush or apply any isopropyl alcohol to the top cover and repeater enclosure.

NOTE: Always use a fresh supply of alcohol and a clean container to prevent contamination by dissolved material (from previous usage).

5.3 Safe Handling of CMOS and LDMOS Devices

Complementary metal-oxide semiconductor (CMOS) devices are used in this family of repeaters, and are susceptible to damage by electrostatic or high voltage charges. Damage can be latent, resulting in failures occurring weeks or months later. Therefore, special precautions must be taken to prevent device damage during disassembly, troubleshooting, and repair.

Handling precautions are mandatory for CMOS circuits and are especially important in low humidity conditions.

DO NOT attempt to disassemble the repeater without first referring to the following CAUTION statement.



Caution

This repeater contains static-sensitive devices. Do not open the repeater unless you are properly grounded. Take the following precautions when working on this unit:

- Store and transport all CMOS devices in conductive material so that all exposed leads are shorted together. Do not insert CMOS devices into conventional plastic “snow” trays used for storage and transportation of other semiconductor devices.
- Ground the working surface of the service bench to protect the CMOS device. We recommend using the Motorola Static Protection Assembly (part number 0180386A82), which includes a wrist strap, two ground cords, a table mat, and a floor mat.
- Wear a conductive wrist strap in series with a 100k resistor to ground. (Replacement wrist straps that connect to the bench top covering are Motorola part number 4280385A59).
- Do not wear nylon clothing while handling CMOS devices.
- Do not insert or remove CMOS devices with power applied. Check all power supplies used for testing CMOS devices to be certain that there are no voltage transients present.
- When straightening CMOS pins, provide ground straps for the apparatus used.
- When soldering, use a grounded soldering iron.
- If at all possible, handle CMOS devices by the package and not by the leads. Prior to touching the unit, touch an electrical ground to remove any static charge that you may have accumulated. The package and substrate may be electrically common. If so, the reaction of a discharge to the case would cause the same damage as touching the leads.

5.4 Repair Procedures and Techniques — General

NOTE Environmentally Preferred Products (EPP) (refer to the marking on the printed circuit boards — examples shown below) were developed and assembled using environmentally preferred components and solder assembly techniques to comply with the European Union's **Restriction of Hazardous Substances (ROHS) Directive 2002/95/EC** and **Waste Electrical and Electronic Equipment (WEEE) Directive 2002/96/EC**. To maintain product compliance and reliability, use only the Motorola specified parts in this manual.

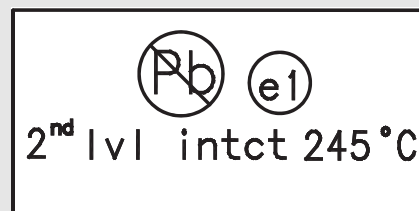
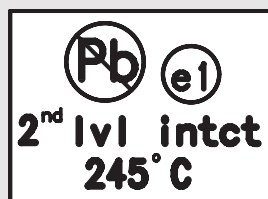

Any rework or repair on Environmentally Preferred Products must be done using the appropriate lead-free solder wire and lead-free solder paste as stated in the following table:

Table 5-1. Lead Free Solder Wire Part Number List

Motorola Part Number	Alloy	Flux Type	Flux Content by Weight	Melting Point	Supplier Part number	Diameter	Weight
1088929Y01	95.5Sn/3.8Ag/0.7Cu	RMA Version	2.7-3.2%	217C	52171	0.015"	1lb spool
1088929Y02	95.5Sn/3.8Ag/0.7Cu	RMA Version	2.7-3.2%	217C	52170	0.010"	0.5lb spool
1088929Y03	95.5Sn/3.8Ag/0.7Cu	RMA Version	2.7-3.2%	217C	52173	0.032"	1lb spool

Table 5-2. Lead Free Solder Paste Part Number List

Motorola Part Number	Manufacturer Part Number	Viscosity	Type	Composition & Percent Metal	Liquid Temperature
1085674C03	NC-SMQ230	900-1000KCPs Brookfield (5rpm)	Type 3 (-325/+500)	(95.5%Sn-3.8%Ag-0.7%Cu) 89.3%	217°C

Parts Replacement and Substitution

When damaged parts are replaced, identical parts should be used. If the identical replacement part is not locally available, check the parts list for the proper Motorola part number and order the part from the nearest Motorola Radio Products and Solutions Organization listed in Appendix A of this manual.

Rigid Circuit Boards

This repeater uses bonded, multi-layer, printed circuit boards. Since the inner layers are not accessible, some special considerations are required when soldering and unsoldering components. The printed-through holes may interconnect multiple layers of the printed circuit. Therefore, exercise care to avoid pulling the plated circuit out of the hole.

When soldering near connector:

- Avoid accidentally getting solder in the connector.
- Be careful not to form solder bridges between the connector pins.
- Examine your work closely for shorts due to solder bridges.

5.5 Disassembling and Reassembling the Repeater — General

The following tools are required for disassembling the repeater:

- Small Flat Blade Screwdriver
- TORX™ T30 Driver Bit
- TORX™ T25 Driver Bit
- TORX™ T20 Driver Bit
- TORX™ T15 Driver Bit
- TORX™ T10 Driver Bit
- 7 mm Magnetic Socket Driver (extension of >150 mm)
- 16 mm Deep Well Socket Driver
- 19 mm Deep Well Socket Driver

If a unit requires more complete testing or service than is customarily performed at the basic level, please send repeater to a Motorola Service Center listed in Appendix A.

The following disassembly procedures should be performed only if necessary.

5.6 Disassembly Procedures — Detailed

The following are typical procedures to remove and replace the Transmit radio, Receive radio, Repeater Indicator Board, connector board assembly and other miscellaneous parts.

1. Power cord and all external cables must be disconnected before opening up repeater.
2. Take the proper grounding precautions as stated in Section 5.3: Safe Handling of CMOS and LDMOS Devices on page 5-2.
3. When disassembling repeater, retain all screws for reuse.

5.6.1 Disassembly of Cover

1. Remove the five screws that retain the cover to the housing as shown in Figure 5-1 using a T20 TORX™ driver.

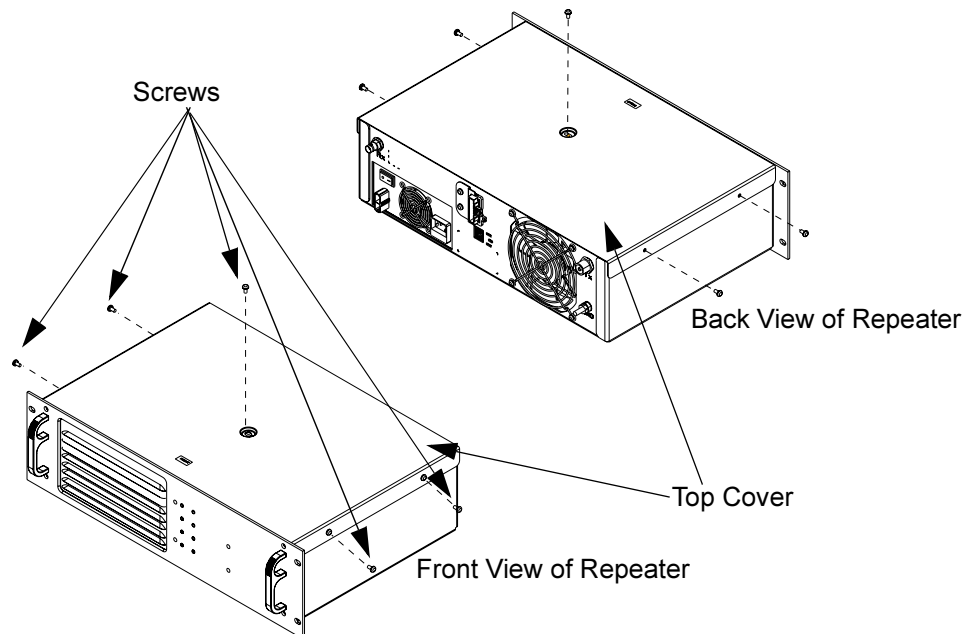

Figure 5-1. Removing Top Cover of Repeater Enclosure

5.6.2 Disassembly of Repeater Indicator Board

(Refer to Figure 5-2 and Figure 5-3)

1. Disconnect the blue ethernet cable from the ethernet connector on the Repeater Indicator Board.
2. Disconnect flex cable from 30-position connector on Repeater Indicator Board, noting orientation of cable which is identified with a solid black line. This is important for reassembly.

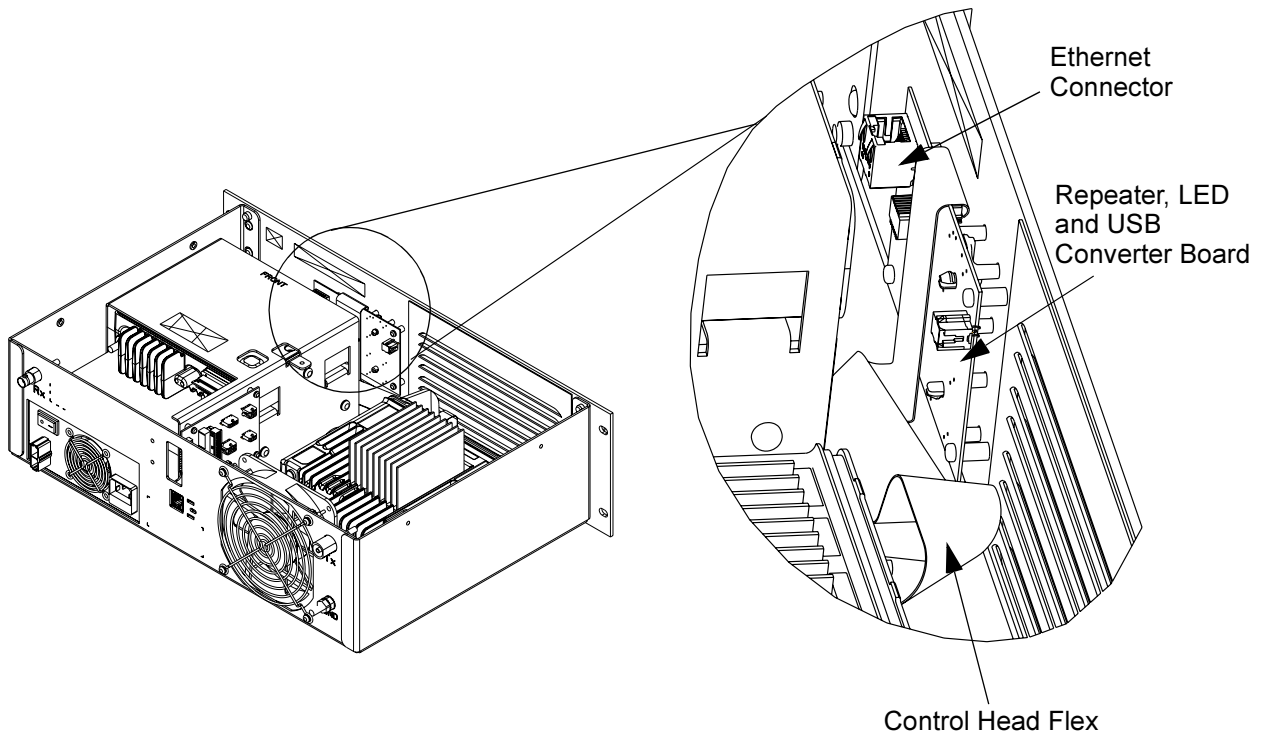

Figure 5-2. Disconnecting Ethernet Cable and Flex Cable

3. Detach the front panel by removing the four M6 screws located on the front face of panel using a T30 TORX™ driver.
4. Place the front panel on a flat surface with the Repeater Indicator Board facing up.
5. Detach the Repeater Indicator Board from front panel by removing the four M3 screws using a T10 TORX™ driver.
6. Hold the Repeater Indicator Board on its outer edge with your finger tips, squeeze together the catch of each clip and slightly press them through the board to remove the light guide.

7. Store Repeater Indicator Board in an anti-static bag when it is not being serviced.

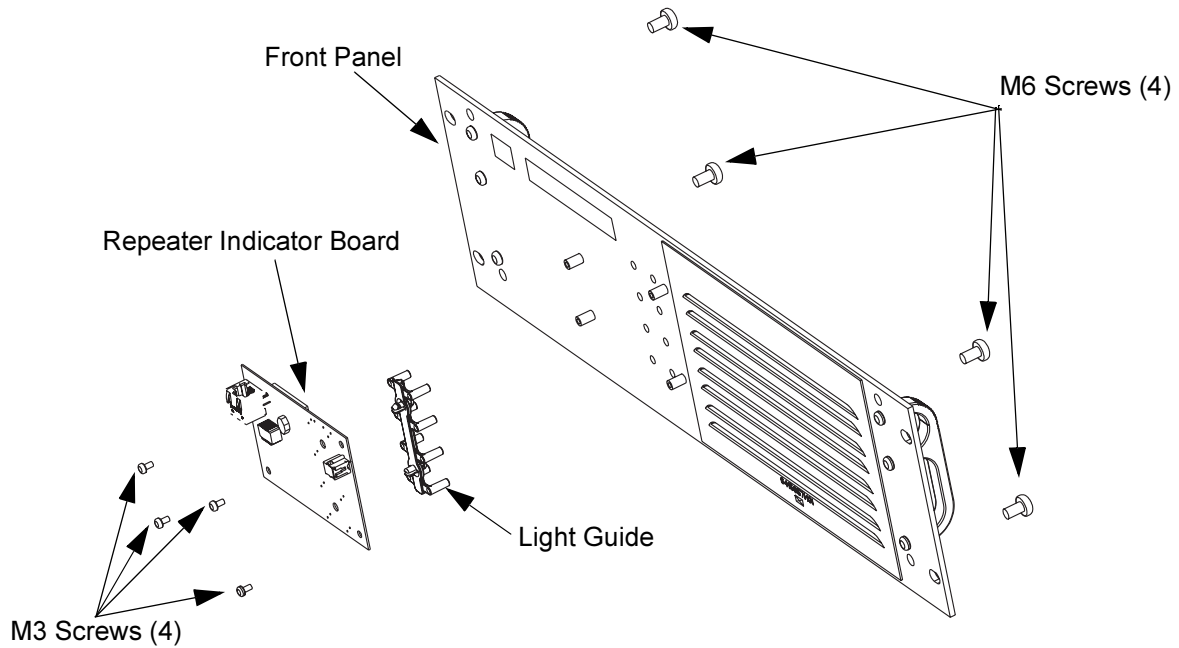

Figure 5-3. Repeater Indicator Board Disassembly

5.6.3 Disassembly of Fan

1. Unplug the fan cable from the mating connector on the connector board assembly.
2. Detach the fan assembly by removing the four screws that secure the fan grill and fan assembly to the back of the enclosure using a T15 TORX™ driver.
3. Carefully remove fan, noting position of arrow which identifies direction of air flow. This is important for reassembly.

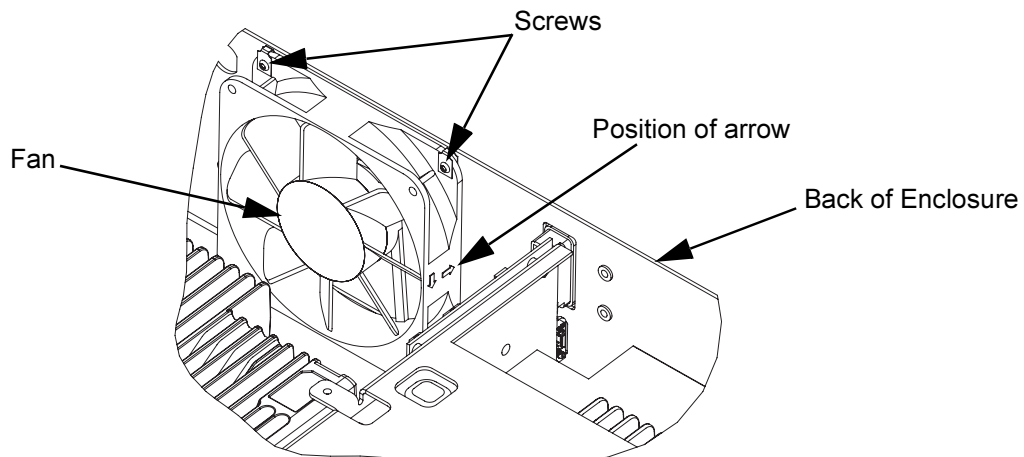

Figure 5-4. Fan Orientation

5.6.4 Removing Transmit Radio

(Refer to Figure 5-5)

1. Disconnect flex cable from 30-position connector on Transmit radio, noting orientation of cable which is identified with a solid blue line. This is important for reassembly.
2. Disconnect SSI flex cable from the connector on the Transmit radio, noting orientation of cable which is identified with a solid black line. This is important for reassembly.
3. Loosen and remove the four M4 lock nuts that secure the Transmit radio assembly with a 7 mm socket driver.
4. Disconnect the power cable from the Transmit radio.
5. Disconnect the antenna cable from the Transmit radio.
6. Disconnect the accessory connector from the Transmit radio.
7. Lift the Transmit radio assembly out of the enclosure and place on a flat surface.
8. Loosen and remove the two M5 screws and washers that secure the Transmit radio to the bracket using a T25 TORX™ driver.

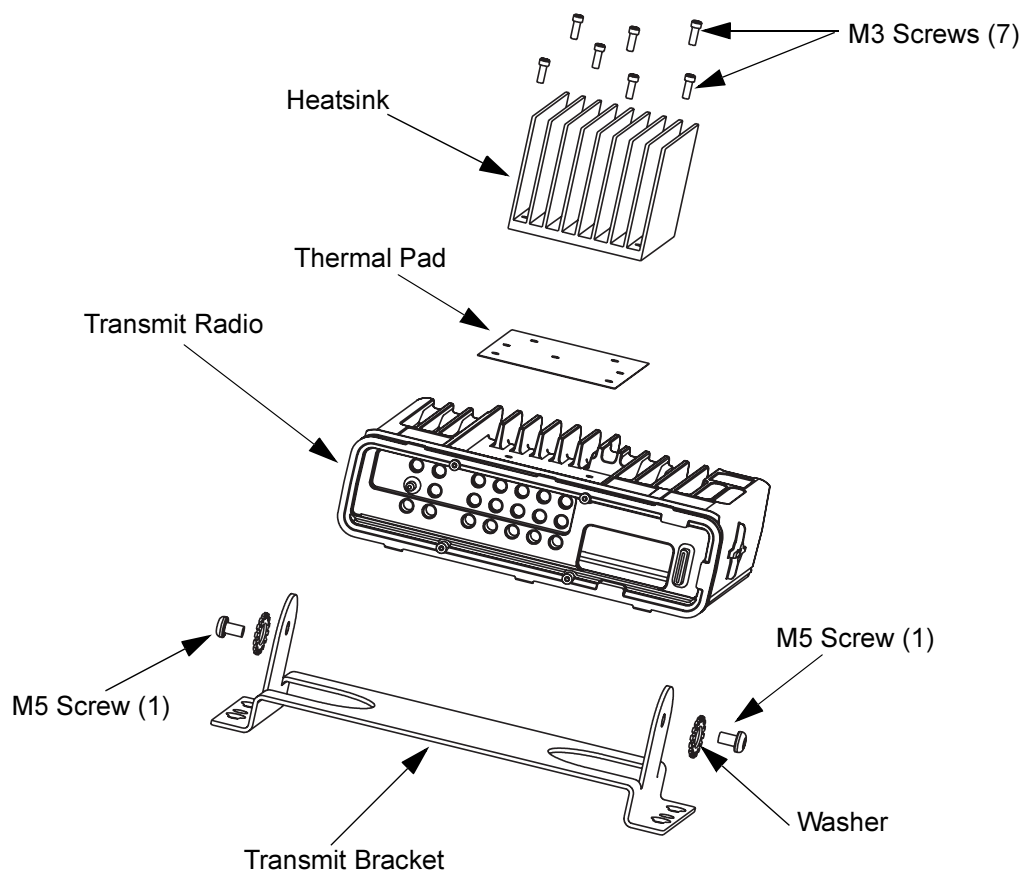

Figure 5-5. Tx Radio Disassembly

5.6.4.1 Removing Thermal Pad and Heatsink

(Refer to Figure 5-5)

1. Remove all of the seven screws which secure the heatsink to the Transmit radio using a T10 TORX™ driver.
2. Remove the heatsink from the Transmit radio.
3. Peel off and discard the thermal pad.
4. Replace all worn parts.

5.6.5 Removing Receive Radio, Power Supply and Connector Board Assembly

(Refer to Figure 5-6)

1. Disconnect SSI flex cable from the connector on the Receive radio, noting orientation of cable which is identified with a dotted line. This is important for reassembly.
2. Disconnect the antenna cable from the Receive radio.
3. Disconnect the power cable from the Receive radio.
4. Remove the two screws securing the retainer clip using a T20 TORX™ driver.
5. Remove accessory connector from the back side of repeater by inserting a flat blade screwdriver into the slot located on the top of the connector.
6. Disconnect all of the cables from their mating connectors located on the connector board assembly.
7. Loosen and remove the five M4 lock nuts that secure the Receive radio assembly with a 7 mm socket driver.

NOTE: The two lock nuts at the side on base will require a magnetic lock nut driver with extension of greater than 150 mm).

8. Slide Receive radio assembly slightly forward before lifting it out of the enclosure.

9. Take precaution not to damage the power supply or the connector board assembly and place assembly on a flat surface.

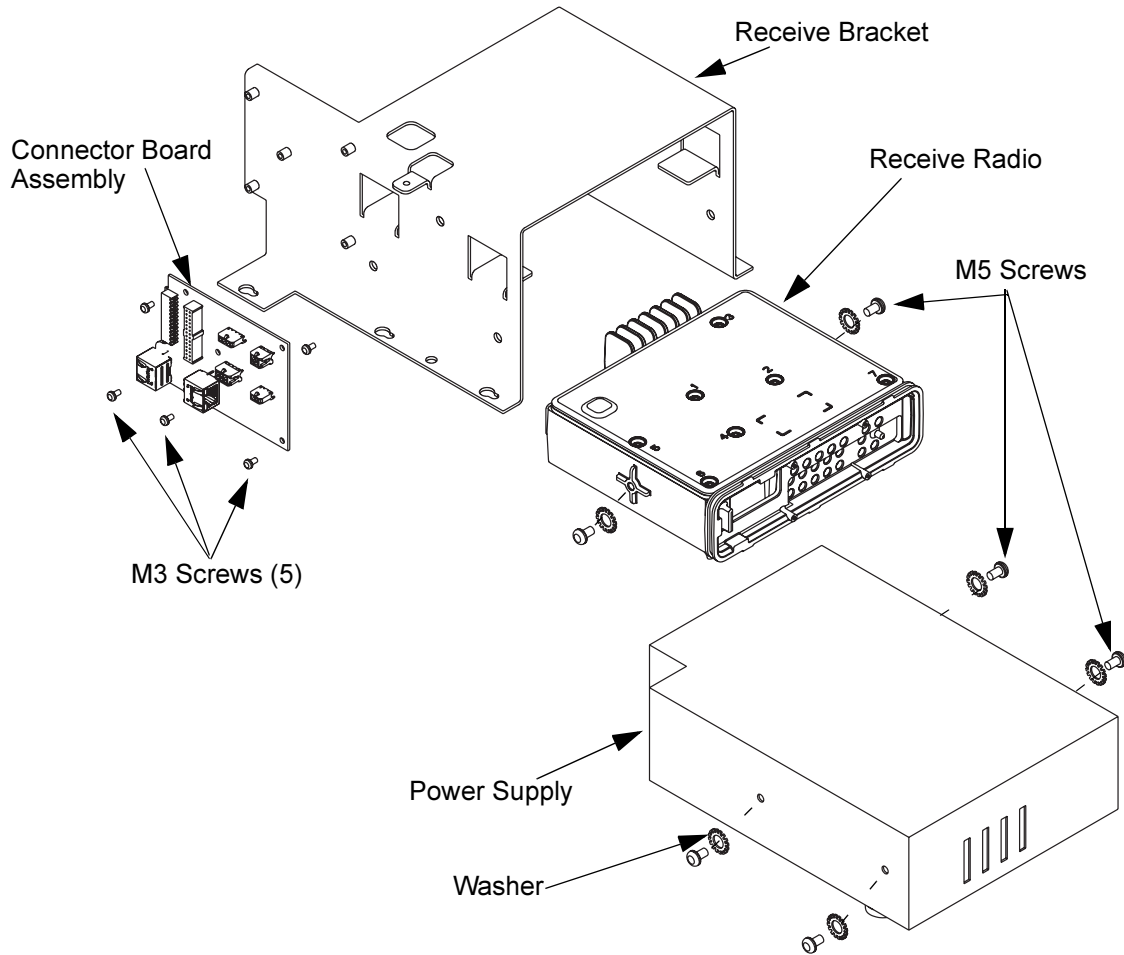

Figure 5-6. Receive Radio Removal

5.6.5.1 Disassembly of Receive Radio

(after Receive radio assembly is removed from repeater)

1. With assembly on a flat surface, loosen and remove the two M5 screws and washers that secure the Receive radio to the bracket using a T25 TORX™ driver.
2. Slide the Receive radio out of the bracket.

5.6.5.2 Disassembly of Connector Board Assembly

(after Receive radio assembly is removed from repeater)

1. With assembly on a flat surface, detach the connector board assembly from Receive radio assembly by removing the five M3 screws using a T10 TORX™ driver.
2. Store connector board assembly in anti-static bag when it is not being serviced.

5.6.5.3 Disassembly of Power Supply

(after Receive radio assembly is removed from repeater)

1. With assembly on a flat surface, loosen and remove the four M5 screws and washers that secure the power supply to the bracket using a T25 TORX™ driver.
2. Slide power supply out from bracket.
3. Disconnect Y-split cable from power supply before sending to manufacturer.

NOTE: Power Supply should be serviced by manufacturer.

5.7 Transmit and Receive Radio Disassembly — Detailed

To remove Transmit and Receive radios from the repeater, refer to Sections 5.6.4 and 5.6.5 accordingly.

5.7.1 Transceiver Board and Receiver Board Removal

1. Remove the seven screws from the die cast cover using the T20 TORX™ driver as shown in Figure 5-7.

NOTE: Do not remove the O-rings from the screws.

2. Lift the die cast cover from the chassis.

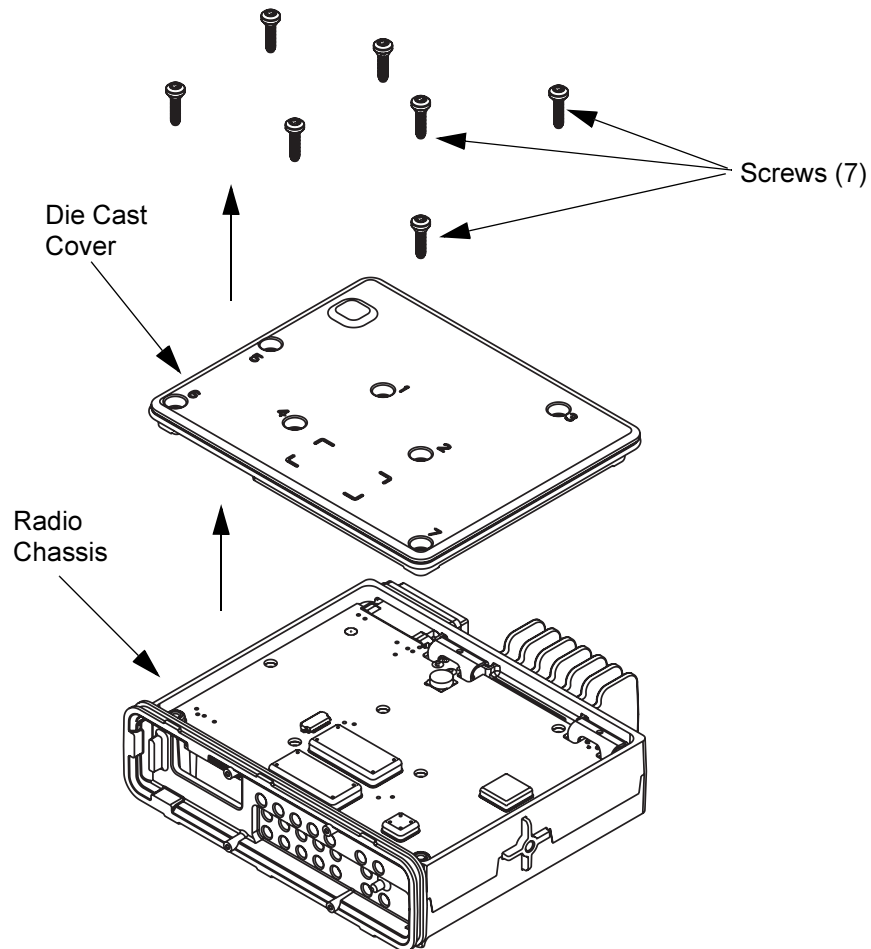

Figure 5-7. Die Cast Cover Removal.

3. Remove the accessory connector from the radio assembly by inserting a flat-blade screwdriver into the slot on the side of the connector as shown in Figure 5-8.

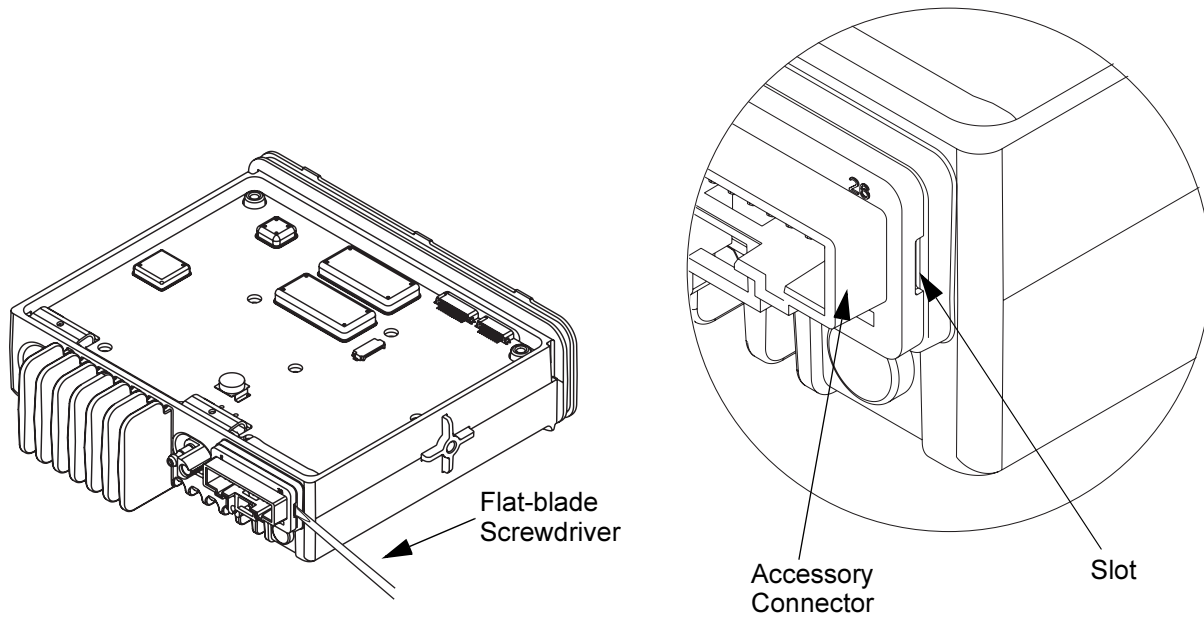
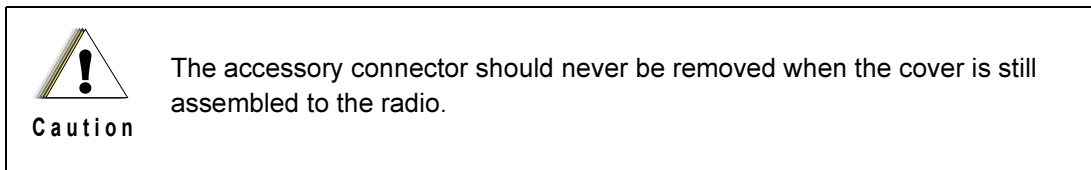

Figure 5-8. Accessory Connector Removal

4. Remove the RF/DC retention clips by gently prying them out with a flat-blade screwdriver as shown in Figure 5-9.

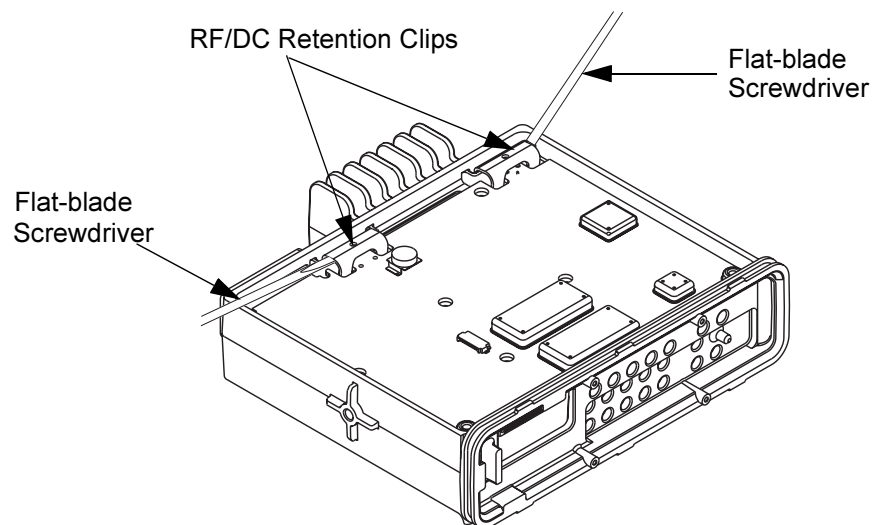

Figure 5-9. RF/DC Retention Clips Removal

5. Remove the transceiver board by sliding a finger into the opening provided at the front of the radio and gently press up on the 30-pin connector, lifting up the front of the board, as shown in Figure 5-10. Then, slide the transceiver board towards the front of the radio to allow the RF/DC connectors to clear the chassis. Handle the transceiver board by the edges only and store it in an antistatic bag.

NOTE: If the RF/DC connector gaskets remain in the chassis, remove them and place them back on the connectors.



Caution

The thermal pads can act as an adhesive and cause stress to critical components on the transceiver board if the transceiver board is lifted too quickly.

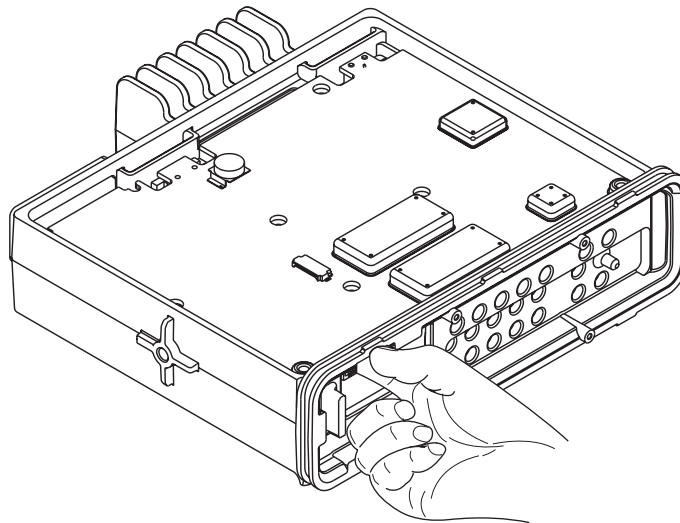

Figure 5-10. Transceiver Board Removal

5.8 Transmit and Receive Radio Reassembly — Detailed

The following reassembly procedures are applicable to both the Transmit and Receive radios.

1. Prior to reassembling the radio, inspect all seals and sealing surfaces for damage (nicks, cuts, etc.) or debris. Refer to the exploded view and bill of materials for the correct part numbers and replace parts, as necessary. Reseat all new seals on their respective parts.

For both the die cast cover and the chassis, thoroughly inspect the shield gasketing for damage and verify all thermal pads are in place and free from damage and debris. See Section 5.8.2: Thermal Pad Replacement Procedure on page 5-19 to replace damaged pads.

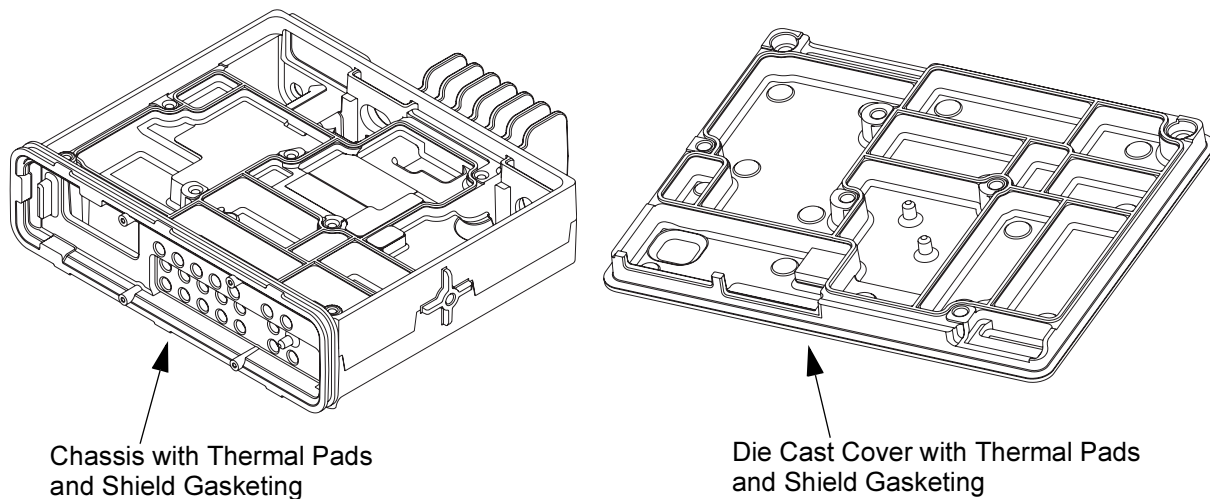

Figure 5-11. Thermal Pads and Shield Gasketing on Chassis and Die Cast Cover

2. Thoroughly inspect the transceiver board and verify all thermal pads are in place and free from damage. See Section 5.8.2: Thermal Pad Replacement Procedure on page 5-19 to replace damaged pads.

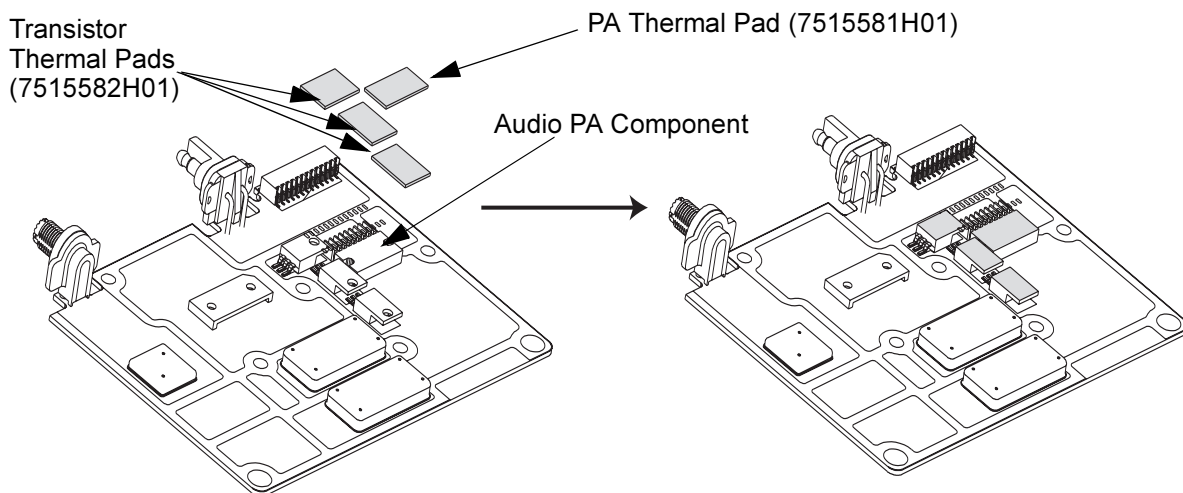

Figure 5-12. Transceiver Board with Thermal Pads

3. Assembly of the GPS Plug
Push the GPS plug into the chassis opening until it is fully seated. Refer to Figure 5-13.

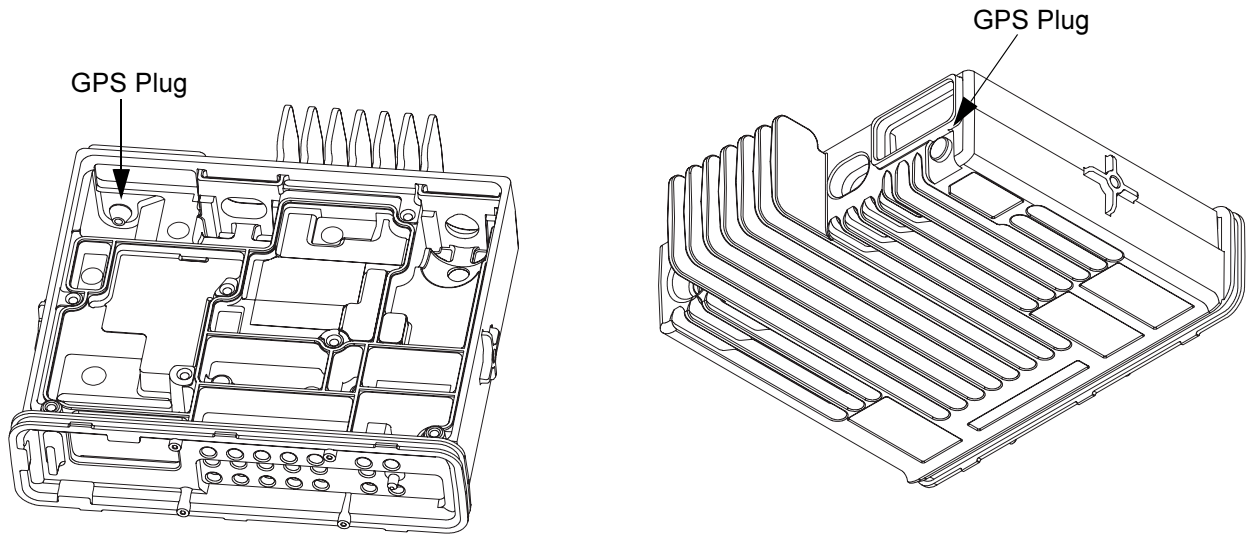

Figure 5-13. Replacing GPS Plug

5.8.1 Transceiver Board and Receiver Board Reassembly

1. Insert the transceiver board into the chassis by tilting the transceiver board (approximately 30 degrees) and sliding it into place, taking care to line up the RF and DC connectors with the openings in the back of the chassis.

Ensure that the transceiver board alignment holes are positioned over the chassis alignment bosses and then push the board down to fully seat.

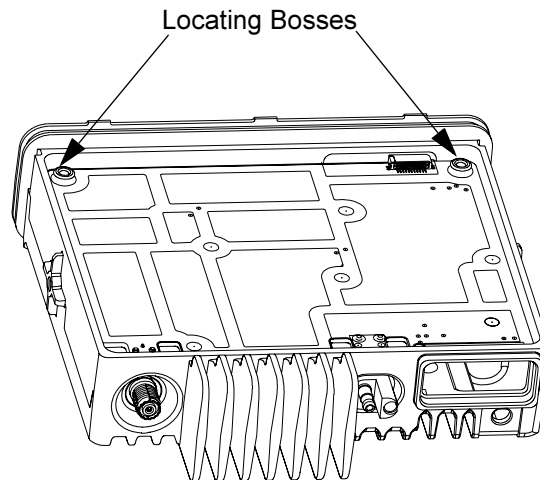

Figure 5-14. Placing the Transceiver Board in the Chassis



Caution

Do not leave the transceiver board in the chassis for extended periods of time without the RF/DC retention clips, or damage to the board connectors may occur.

2. Insert the RF/DC retention clips and fully seat them. The DC clip should be inserted first to properly locate the transceiver board. Refer to Figure 5-15.

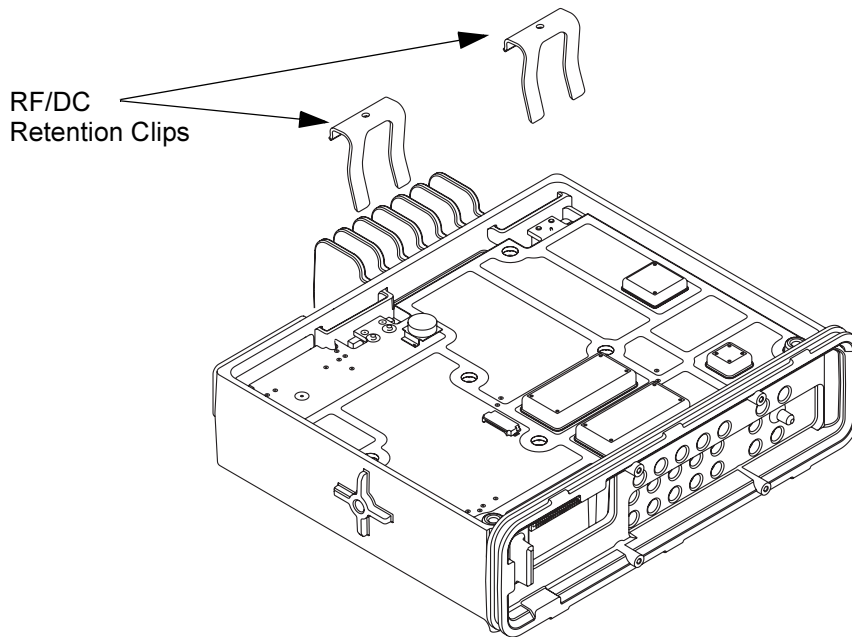

Figure 5-15. Inserting RF/DC Retention Clips

3. Insert the accessory connector into the radio assembly and press into place until the connector is flushed with the chassis. Refer to Figure 5-16.

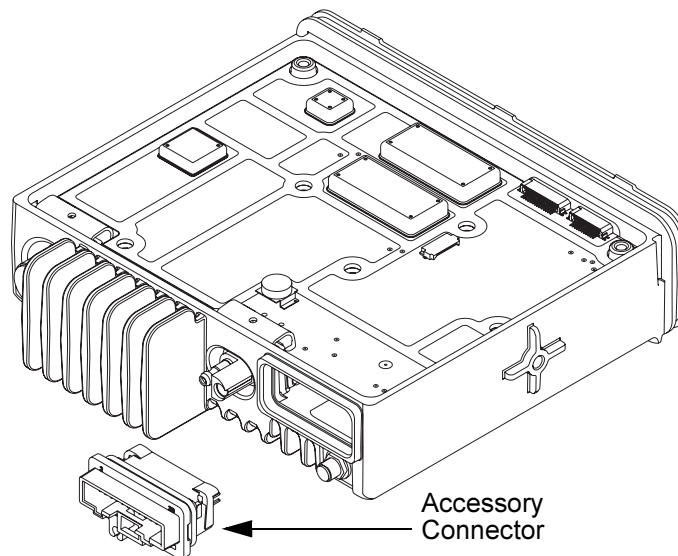

Figure 5-16. Inserting Accessory Connector

4. Place the PA pad on to the die cast cover by aligning the two holes in the PA pad with the alignment pins on the die cast cover.
5. Fit the O-ring onto the die cast cover securely. Refer to Figure 5-17.

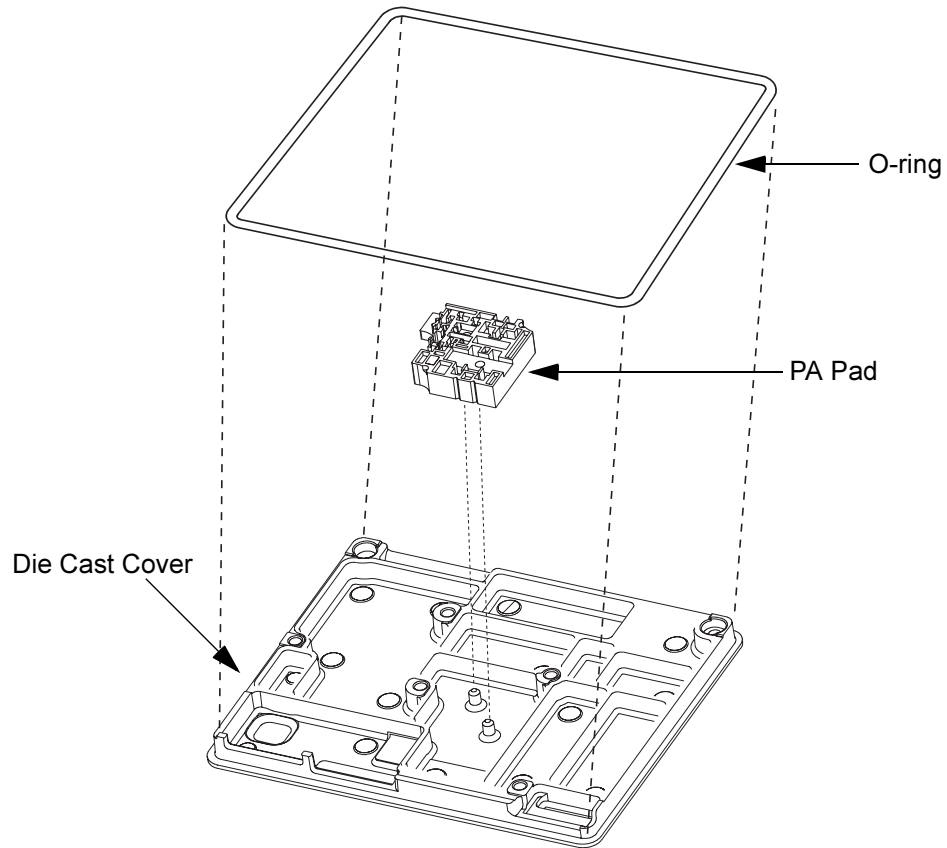

Figure 5-17. Assembling of PA Pad and O-ring

- Place the die cast cover onto the chassis orienting the die cast cover so that screw holes 6 and 7 align with the bosses on the chassis as shown in Figure 5-18.

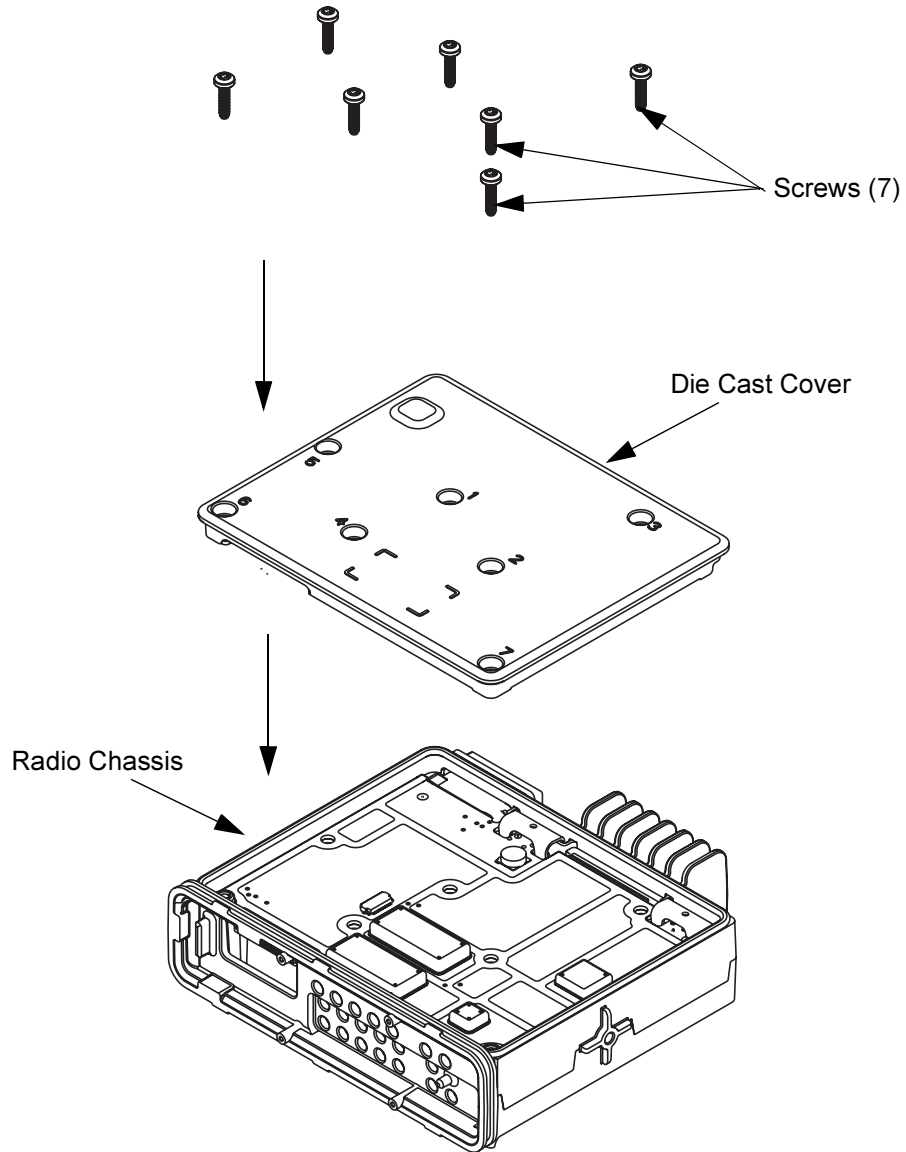

Figure 5-18. Assembling Die Cast Cover onto Chassis

7. Using a T20 TORX™ driver, tighten the seven screws between 2.94 N-m (26 lbs-in) in the order shown in Figure 5-19.
8. Repeat tightening the seven screws in the order shown otherwise the first three screws will likely be loose.

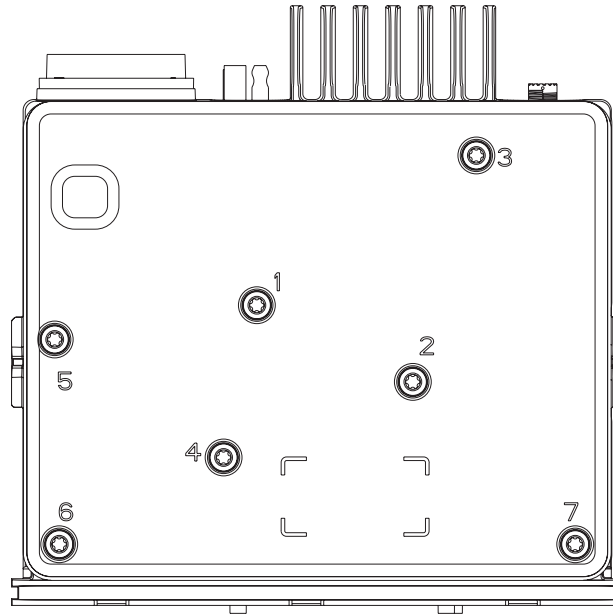

Figure 5-19. Screw Sequence to Tighten Die Cast Cover

5.8.2 Thermal Pad Replacement Procedure

A. Chassis Thermal Pad Replacement Procedure

Harmonic Filter Thermal Pad Replacement

1. Use a plastic flat-edge tool to lift the pad from the chassis surface. Discard the old pad.
2. Use a soft cloth to remove any remaining residue. Alcohol can also be used, if necessary. Care should be taken to minimize any cleaning-agent contact with the surrounding shield gasket.
3. Once the surface is clean and dry, remove the new pad from the shipping liner, and place it white side down on the chassis as shown in Figure 5-20.

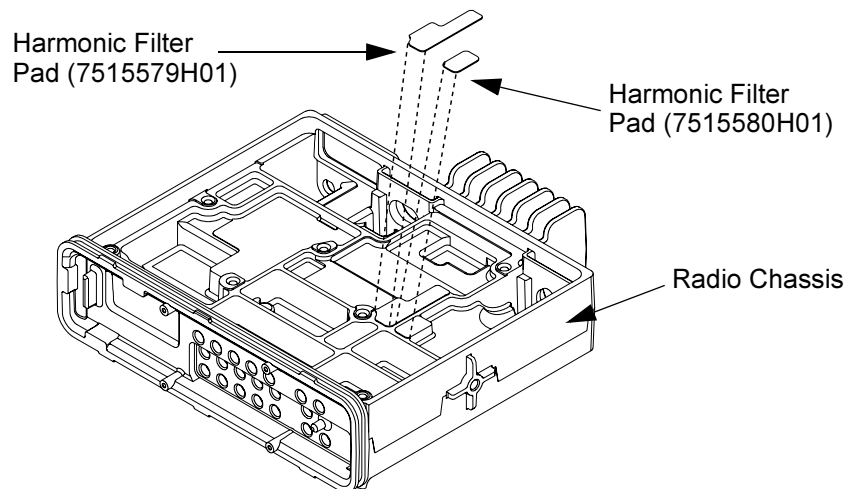

Figure 5-20. Replacing Thermal Pads

Driver Thermal pad Replacement

1. Use a plastic flat-edge tool to lift the pad from the chassis surface. Discard the old pad.
2. Use a soft cloth to remove any remaining residue. Alcohol can also be used, if necessary. Care should be taken to minimize any cleaning-agent contact with the surrounding shield gasket.
3. Once the surface is clean and dry, remove the new pad from the shipping liner, and place the pad on to the chassis, aligning the edges of the pad with the edges of the chassis, as shown in Figure 5-21.

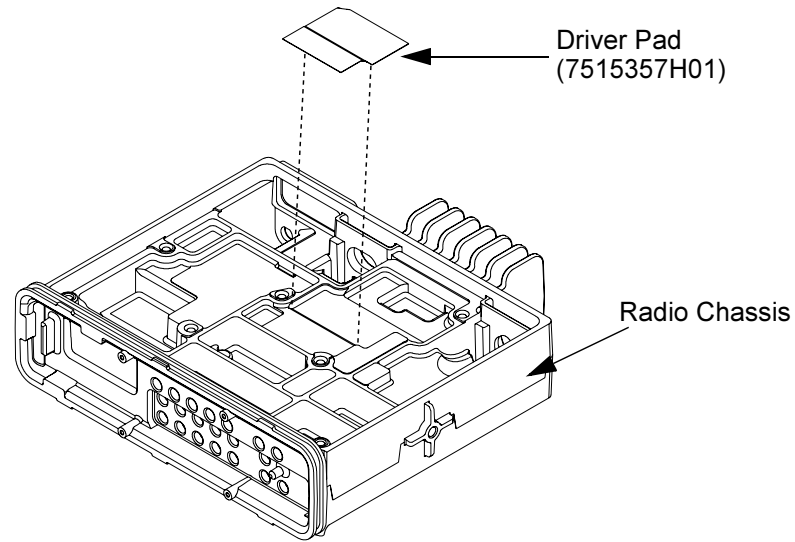

Figure 5-21. Aligning Driver Pad on Chassis

4. Apply even pressure to the pad and remove the protective liner.

B. Transceiver Board Thermal Pad Replacement Procedure

Transistor Thermal Pads and PA Thermal Pad Replacement

1. Use a plastic flat-edge tool to lift each pad from the transceiver board. Discard the old pads.
2. Use a soft cloth to remove any remaining residue. Alcohol can also be used, if necessary.
3. Once the surface is clean and dry, remove each new pad from the shipping liner, and place in the proper location on top of each transistor component and the audio PA with the white side down (see Figure 5-22).

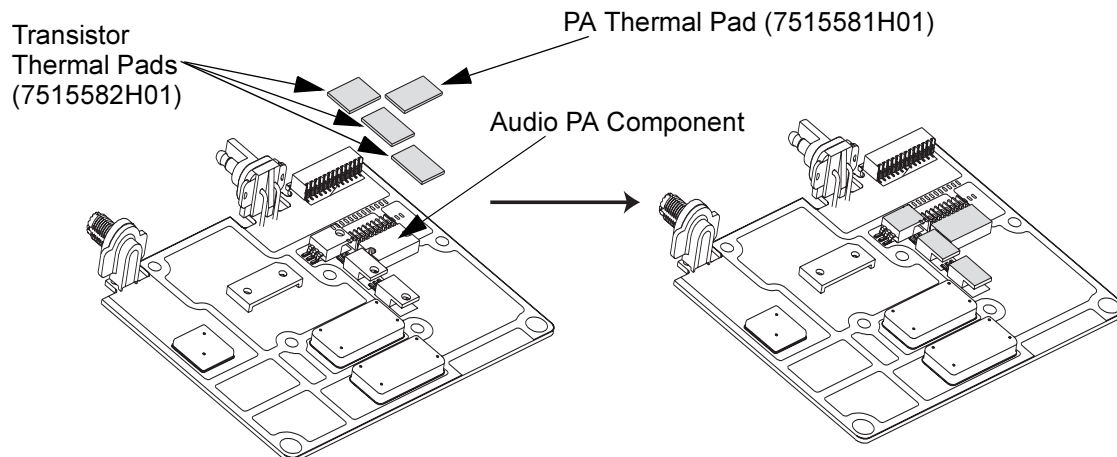

Figure 5-22. Placing Thermal Pads on PA and Transistor Components

5.8.3 Reassembly of Receive Radio, Power Supply and Connector Board Assembly

(Refer to Figure 5-6)

Visually inspect repeater enclosure to ensure that no metal shavings or debris are found.

5.8.3.1 Reassembly of Power Supply

1. Align the two mounting holes on each side of the bracket with the mounting holes on the power supply.
2. Secure the power supply and the bracket with four M5 screws and washers.
3. Tighten the four M5 screws to 3.0 N-m.
4. Firmly connect the single connection end of Y-split cable to power cable of power supply.

5.8.3.2 Reassembly of Receive Radio

1. Insert the Receive radio into the top half of the bracket.
2. Align mounting hole on each side of the receive chassis to the mounting holes on the bracket.
3. Secure the Receive radio and the bracket with two M5 screws and washers.
4. Tighten the two M5 screws to 3.0 N-m.

5.8.3.3 Reassembly of Connector Board Assembly

1. Align the five mounting holes on the connector board assembly onto the five standoffs on the receive bracket and install five M3 screws.
2. Tighten the five M3 screws to 1.0 N-m.

5.8.3.4 Reassembly of the Receive Bracket Assembly to the Enclosure

1. Align and mount the receive bracket assembly onto the five stud screws in the enclosure.
2. Ensure that the dimple locator (bump) on the enclosure is nested within the hole on the receive bracket before installing and tightening the lock nuts.
3. Tighten the five lock nuts to 2.0 N-m.

NOTE: The two lock nuts at the side on base will require a magnetic lock nut driver with extension of greater than 150 mm).

4. Connect the antenna cable to the Receive radio.
5. Insert the BNC connector of the antenna cable through the back panel of the enclosure and secure it using a lock washer and nut.
6. Tighten the nut to 0.7 N-m using a 16 mm deep well socket driver.
7. Firmly connect one of the connectors from the dual end of Y-split cable to the Receive radio.

NOTE: All cables (except the antenna cable), are routed at the bottom rear receive bracket.

8. Insert the accessory connector through the opening of the enclosure onto the edge of the connector board assembly.
9. Make sure that the accessory connector is completely inserted onto the connector board assembly and the back end surface of the accessory connector is flushed firmly against the back panel of enclosure.
10. Mount the retainer clip and secure it with two M4 screws.
11. Tighten the screws to 2.0 N-m.

12. Insert the solder terminal end of the SSI cable into the 11-position connector at the front face of Receive radio. A dashed black line is visible from the top view.

5.8.4 Reassembly of Transmit Radio

(Refer to Figure 5-5)

5.8.4.1 Replacing the Thermal Pad and Heatsink

1. Make sure that mating surfaces of Heatsink and Transmit radio are cleaned and free from any debris.
2. Align the holes on the thermal pad to the screw holes in the Transmit radio and place thermal pad onto the Transmit radio.
3. Align the holes on the heatsink to the screw holes in the Transmit radio and place heatsink onto the thermal pad.
4. Secure but do not tighten the seven screws previously removed.
5. When all seven screws are secured, tighten the screws to 1.0 N-m. Refer to Figure 5-19.

5.8.4.2 Reassembly of the Transmit Bracket Assembly to the Enclosure

1. Position the Transmit radio onto the transmit bracket so that the label "FRONT" on bracket is facing the front face of radio.
2. Align the mounting holes on the Transmit radio and the transmit bracket on both sides.
3. Attach and secure the M5 screws and washers on each side of the bracket.
4. Tighten the screws to 3.0 N-m, making sure the Transmit radio remains horizontal.
5. Align and mount the transmit bracket assembly onto the four stud screws in the enclosure.
6. Ensure that dimple locator (bump) on the enclosure is nested within the hole on the transmit bracket before installing and tightening the lock nuts.
7. Secure the four lock nuts (two on each side) onto the stud screws.
8. Tighten the four lock nuts to 2.0 N-m.
9. Connect the antenna cable to the Transmit radio.
10. Insert the N-Type connector of the antenna cable through the back panel of the enclosure and secure it using a lock washer and nut.
11. Tighten the nut to 0.7 N-m using a 19 mm deep well socket driver.
12. Firmly connect one of the connectors from the dual end of Y-split cable to the Transmit radio.
13. Connect the black colored end of accessory cable connector to rear of Transmit radio making sure that the locking connector tab is facing up.
14. Connect the white colored end of the accessory cable connector to the connector board assembly making sure that the locking connector tab is facing toward the front of repeater.

NOTE: Make sure that the accessory connectors at both ends are locked in place. A clicking sound can be heard from the locking tab.

15. Insert the solder terminal end of the SSI flex cable (positioned bottom side of PCB) into the 11-position connector in the Transmit radio. A solid black line is visible from the top view.
16. Insert the solder terminal end of the flex cable (positioned top side of PCB) into the 30-position connector in the Transmit radio. A solid blue line is visible from the top view.

5.8.5 Reassembly of Fan

1. Position the fan in the enclosure with arrow pointing outward and the wires on the fan at the bottom right corner of the fan.

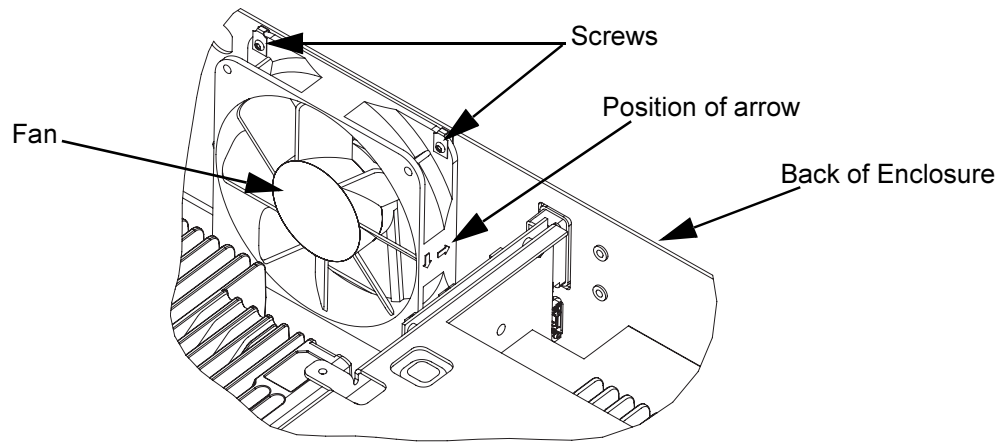

Figure 5-23. Fan Orientation

2. Position the fan grill outside of the enclosure aligning with the screw holes.
3. Install four 3.5 mm screws through the fan grill, the rear panel of the enclosure and onto the fan clip.
4. Secure the fan and tighten the four screws to 1.2 N-m through each of the fan clip.
5. Plug the fan cable plug into the 4-position fan connector on the connector board assembly.

NOTE: It is recommended that you dress and tie wrap the blue ethernet cable and the fan cables.

5.8.6 Reassembly of Repeater Indicator Board

Refer to Figure 5-3.

1. Holding Repeater Indicator Board on outer edge, insert the clips of light guide into mounting holes, making sure the light guide snaps into place.
2. Align the four mounting holes on the Repeater Indicator Board onto the four standoffs on the front panel.
3. Install and secure the four M3 screws.
4. Tighten the four M3 screws to 1.0 N-m.
5. Use the four M6 screws to secure the front panel onto the enclosure. Tighten the screws to 3.7 N-m.
6. Connect the blue ethernet cable onto the ethernet connector on the Repeater Indicator Board.
7. Insert the flex cable onto the 30-position connector on the Repeater Indicator Board. The solder terminal end of the flex cable is faced towards the front panel. A solid black line is visible from the top view.

5.8.7 Reassembly of Cover

1. Place the cover on the enclosure.
2. Secure the two M4 screws on each side of the cover and one at the top. Tighten the screws to 2.0 N-m.

5.9 Repeater Exploded Mechanical Views and Parts Lists

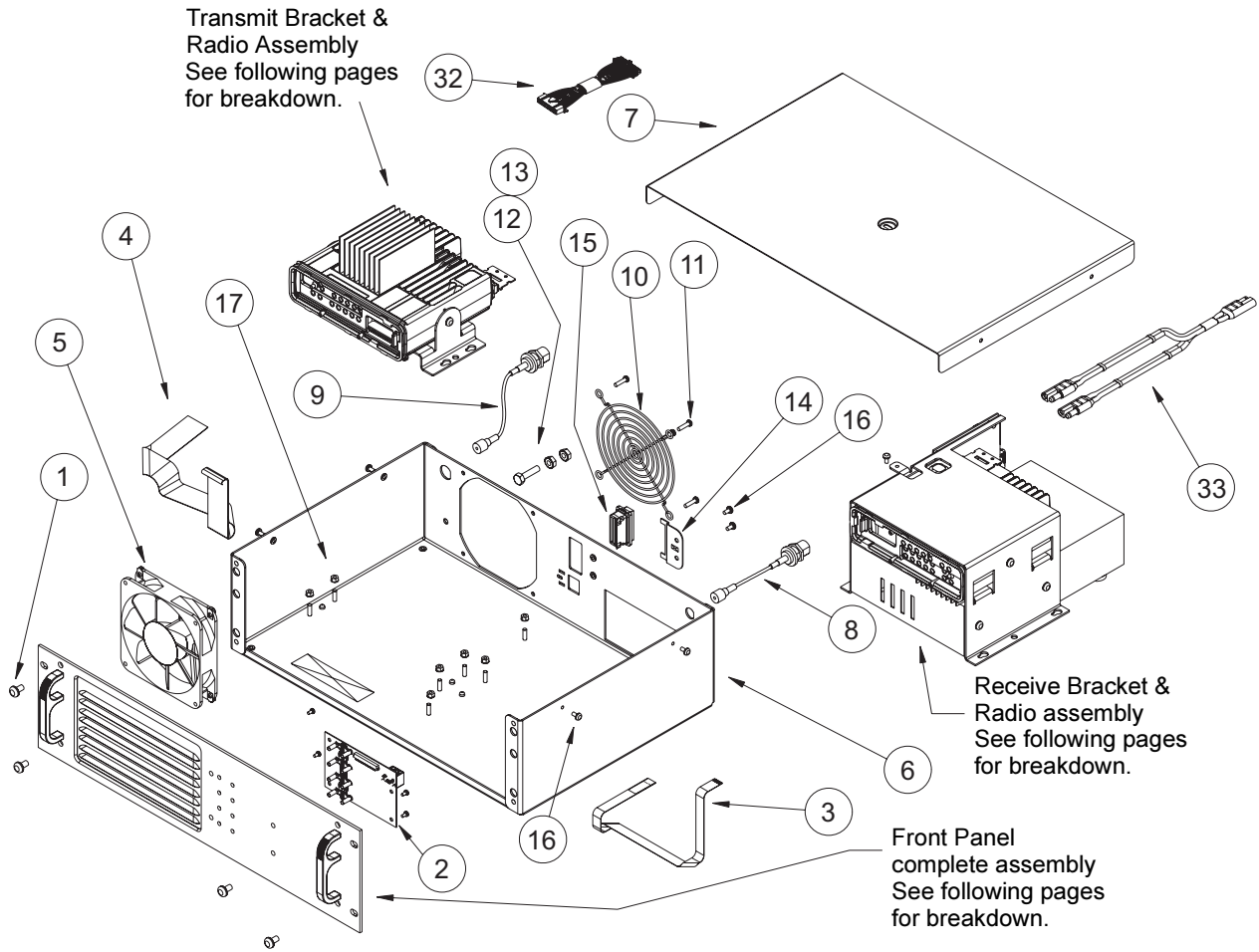

Figure 5-24. Repeater Assembly Exploded View

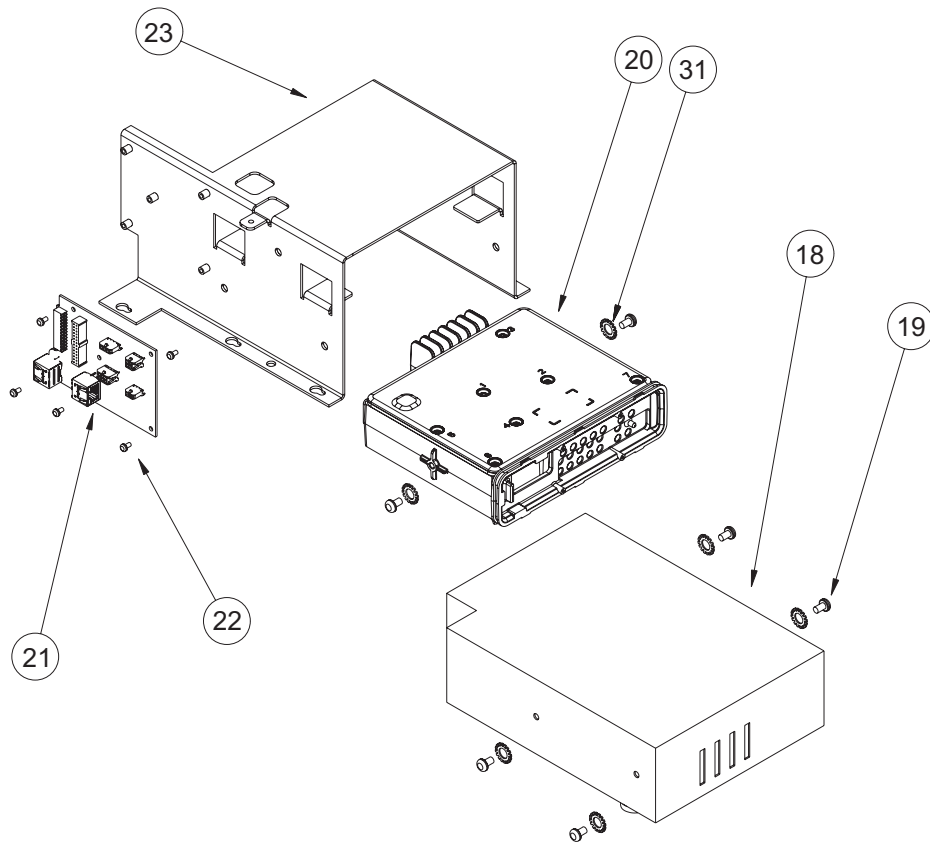

Figure 5-25. Receive Bracket and Radio Assembly Exploded View

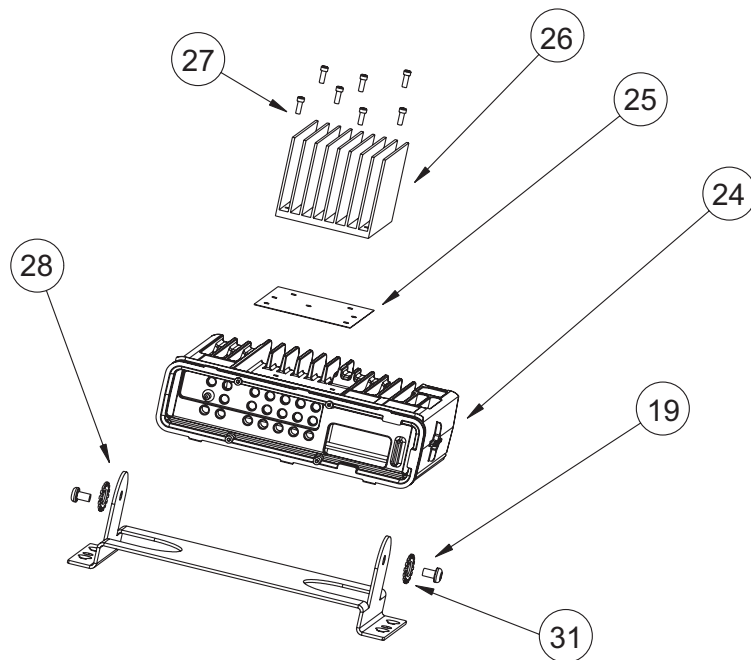

Figure 5-26. Transmit Bracket and Radio Assembly Exploded View

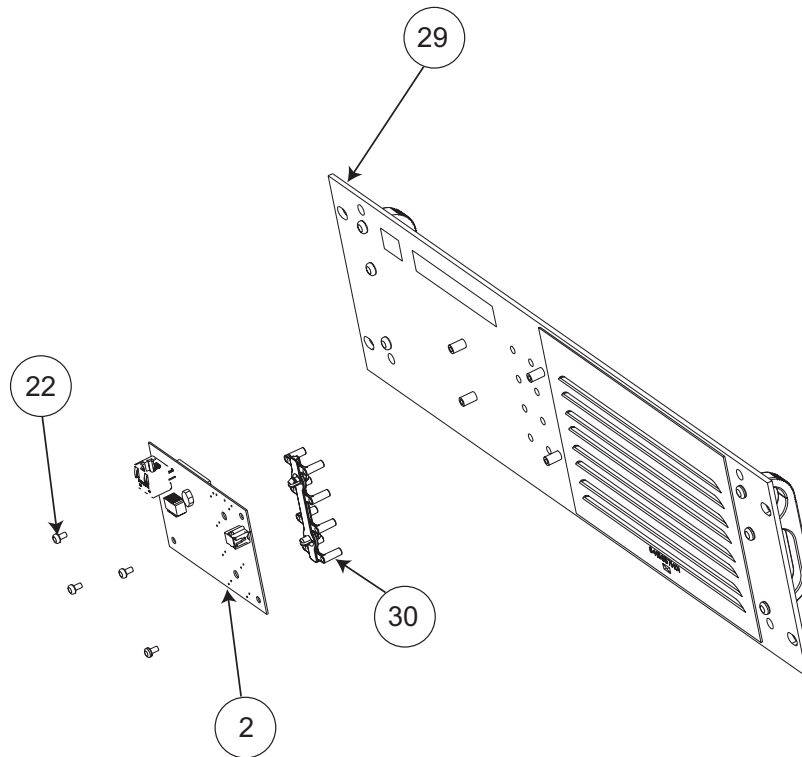

Figure 5-27. Front Panel Complete Assembly Exploded View

Table 5-3. Repeater Exploded View Parts List

Item No.	Description	Part Number
1	Screw, TT6x1.0x10, Starpan, EM6219 (black)	0312016A54
2	Repeater Indicator Board	PMLN4814_
3	Cable, Flex SSI	3015639H01
4	Cable, Flex 30-Position	3015634H01
5	Fan Assembly	5915618H01
6	Enclosure Assembly	1515837H01
7	Top Cover	1515655H01
8	Cable, RF Tx, W/N-Type	3015573H01
9	Cable, RF Rx, W/BNC	3015574H01
10	Fan Grill	1383852R01
11	Screw, TT3.5x0.6x16, Star SLT Pan	0310909E50
12	M6 Ground Nut	0285854Y01
13	M6 Ground Screw	0310909A95
14	Accessory Retainer Clip	4216361H01
15	Accessory Connector	0178042A01
16	Screw, M4x0.7x13.0, Starpan STLZNC	0310909E63

Table 5-3. Repeater Exploded View Parts List

Item No.	Description	Part Number
17	Lock Nut M4	0285854Y02
18	Power Supply	PMPN4001_
19	Screw, M5x0.8x8.0, Starpan STLZNC	0310909A74
20	Receive Radio Brick Assembly	PMTE4004_
21	Connector Board Assembly	PMLN4815_
22	Screw, M3x0.5x5, Starpan STLZNC	0310909A30
23	RX Bracket Assembly	0715656H01
24	Transmit Radio Brick Assembly	PMTE4004_
25	Thermal Pad	7515633H01
26	Heatsink	2615620H01
27	Screw, M3x0.5x10, Starpan STLZNC	0310909A33
28	Tx Bracket	0715654H01
29	Front Panel Assembly only (handles not included)	6415658H04
30	Light Guide	6116326H01
31	Washer	0400002647
32	Cable Assembly, Tx to Connector Board	3015570H01
33	Cable, Power, Y-Split	3085859M01

5.10 Torque Chart

Table 5-4 lists the various nuts and screws by part number and description, followed by the torque values in different units of measure. Torque all screws to the recommended value when assembling the repeater.

Table 5-4. Torque Specifications for Nuts and Screws

Part Number	Description	Driver/ Socket	Torque		
			N-m	lbs-in	kg-cm
0285854Y01	Grounding Nut, M6	10 mm dip socket	2.0	17.70	20.4
0285854Y02	Lock Nut, M4 x 0.8, ext tooth	7 mm socket	2.0	17.70	20.4
0310909A30	Screw, M3.0 x 0.5 x 5 mm	T10 Torx™	1.0	8.9	10.2
0310909A33	Screw, M3 x 0.5 x 10 mm	T10 Torx™	1.0	8.9	10.2
0310909A74	Screw, M5 x 0.8 x 8 mm	T25 Torx™	3.0	26.6	30.6
0310909E50	Screws, M3.5 x 0.5 x 16 mm	T15 Torx™	1.2	10.6	12.2
0310909A95	Grounding Screw, M6 x 1 x 25	T30 Torx™	2.0	17.7	20.4
0312016A54	Screws, TT6 x 1.0 x 10 mm Star Thread Rolling Screw	T30 Torx™	3.7	32.7	37.7
0310909E63	Screw, M4 x 0.7 x 7 mm, Slotted Star	T20 Torx™	2.0	17.7	20.4
3015574H01	BNC Type connector	16 mm deep well socket	0.7	6.2	7.1
3015573H01	N Type connector	19 mm deep well socket	0.7	6.2	7.1

Notes

Chapter 6 Basic Troubleshooting

6.1 Introduction

This chapter contains error codes and board replacement procedures. If the repeater does not pass all the performance checks in Chapter 3, then please send the repeater to a Motorola Service Center listed in Appendix A.

NOTE: To access the various connector pins, use the housing eliminator/test fixture along with the diagrams found in this section of the manual. (See Section, "Service Aids" on page 2-2, for the appropriate Motorola service aids and tools part numbers.)

6.1.1 High Power RF Precaution



Caution

The repeater might transmit while the technician believes the radio is in receive mode under the following conditions: radio failure, digital affiliation, a defective PTT button, or other unintentional activations.

To avoid possible equipment damage, when performing both transmit and receive tests, a suitable attenuator rated at 100 W or more should always be used with test equipment connected to the RF connector. The only exception to this is when the equipment's input power rating is higher than the maximum output power of the repeater.

6.2 Replacement Service Kit Procedures

Once a problem has been isolated to a specific board, install the appropriate service kit (see Model Chart in Section 1.4 on page 1-3), which is orderable from Motorola Radio Products and Solutions Organization, see Appendix A. Refer to <http://emeaonline.motorola.com> for further information.

- If a board is replaced, it does not necessarily need to be retuned if it has been factory tuned. It should however be checked for performance before being placed into service. Of particular concern is the Bias DAC, which will need to be set for the appropriate final device bias current prior to keying up the radio. If the bias is not properly set it may be possible to cause damage to the transmitter.



Caution

The Tuner Tool only allows the serial number of a blank board to be entered once. Be very attentive during this procedure.

6.3 LED Indicator Descriptions

Table 6-1. LED Indicator Descriptions

LED	Status	Description
Power	Solid GREEN	Repeater powered by AC
	Solid RED	Repeater powered by back-up battery
	Off	Repeater powered off
Repeater Disable	Solid RED	Repeater function disabled
	Blinking RED	Repeater in self test mode
	Off	Repeater in normal operational mode
Digital	Solid BLUE	Repeater in Digital mode
Analog	Solid YELLOW	Repeater in Analog mode
TX-A	Solid GREEN	Repeater transmitting (Analog)
	Solid GREEN	Repeater transmitting on Slot A (Digital)
RX-A	Solid YELLOW	Repeater receiving (Analog)
	Solid YELLOW	Repeater receiving on Slot A (Digital)
TX-B	Solid GREEN	Repeater transmitting on Slot B (Digital)
RX-B	Solid YELLOW	Repeater receiving on Slot B (Digital)

Appendix A EMEA Regional Warranty, Service and Technical Support

1.0 Warranty and Service Support

Motorola offers long term support for its products. This support includes full exchange and/or repair of the product during the warranty period, and service/ repair or spare parts support out of warranty. Any "return for exchange" or "return for repair" by an authorized Motorola Dealer must be accompanied by a Warranty Claim Form. Warranty Claim Forms are obtained by contacting an Authorized Motorola Dealer.

1.1 Warranty Period and Return Instructions

The terms and conditions of warranty are defined fully in the Motorola Dealer or Distributor or Reseller contract. These conditions may change from time to time and the following notes are for guidance purposes only.

In instances where the product is covered under a "return for replacement" or "return for repair" warranty, a check of the product should be performed prior to shipping the unit back to Motorola. This is to ensure that the product has been correctly programmed or has not been subjected to damage outside the terms of the warranty.

Prior to shipping any radio back to the appropriate Motorola warranty depot, please contact Customer Resources (Please see page A-3). All returns must be accompanied by a Warranty Claim Form, available from your Customer Services representative. Products should be shipped back in the original packaging, or correctly packaged to ensure no damage occurs in transit.

1.2 After Warranty Period

After the Warranty period, Motorola continues to support its products in two ways.

1. Motorola's Managed Technical Services (MTS) offers a repair service to both end users and dealers at competitive prices.
 2. MTS supplies individual parts and modules that can be purchased by dealers who are technically capable of performing fault analysis and repair.
-

2.0 European Radio Support Centre (ERSC)

The ERSC Customer Information Desk is available through the following service numbers:

Austria:	08 00 29 75 41	Italy:	80 08 77 387
Belgium:	08 00 72 471	Luxemburg:	08 00 23 27
Denmark:	80 88 05 72	Netherlands:	08 00 22 45 13
Finland:	08 00 11 49 910	Norway:	80 01 11 15
France:	08 00 90 30 90	Portugal:	08 00 84 95 70
Germany:	08 00 18 75 240	Spain:	90 09 84 902
Greece:	00 80 04 91 29 020	Sweden:	02 07 94 307
UK :	08 00 96 90 95	Switzerland:	08 00 55 30 82
Ireland:	18 00 55 50 21	Iceland:	80 08 147

Or dial the European Repair and Service Centre:
Tel: +49 30 6686 1555

Please use these numbers for repair enquiries only.

3.0 Piece Parts

Some replacement parts, spare parts, and/or product information can be ordered directly. If a complete Motorola part number is assigned to the part, it is available from Motorola Radio Products and Solutions Organization (RPSO). If no part number is assigned, the part is not normally available from Motorola. If the part number is appended with an asterisk, the part is serviceable by Motorola Depot only. If a parts list is not included, this generally means that no user-serviceable parts are available for that kit or assembly.

Orders for replacement parts, kits and assemblies should be placed directly on Motorola's local distribution/dealer organisation or via Motorola Online at: <http://emeaonline.motorola.com>

* The Radio Products and Solutions Organization (RPSO) was formerly known as the Radio Products Services Division (RPSD) and/or the Accessories and Aftermarket Division (AAD).

4.0 Technical Support

Motorola Product Services is available to assist the dealer/distributors in resolving any malfunctions which may be encountered.

North Europe - Stephen Woodrow
Telephone: +44 (0) 1256 488 082
Fax: +44 01256 488 080
Email: CSW066@motorola.com

Central and East Europe - Sigggy Punzenberger
Telephone: +49 (0) 6128 70 2342
Fax: +49 (0) 6128 95 1096
Email: TFG003@email.mot.com

Russia and Belarus - Sergey An
Telephone: +7 495 785 0150
Fax: +7 495 785 0185
Email: CSA002@email.mot.com

Germany - Customer Connect Team
Telephone: +49 (0) 30 6686 1539
Fax: +49 (0) 30 6686 1916
Email: cgiss.emea@europe.mot.com

Middle East and Africa - Wayne Holmes
Telephone: +27 11 800 7922
Fax: +27 11 800 7923
Email: radiosupport.za@motorola.com

Italy - Ugo Gentile
Telephone: +39 0 2822 0325
Fax: +39 0 2822 0334
Email: C13864@email.mot.com

France - Armand Roy
Telephone: +33 1 6935 7868
Fax: +33 1 6935 7808
Email: armand.roy@motola.com

France - Laurent Irrmann
Telephone: +33 1 6935 7866
Fax: +33 1 6935 7808
Email: laurent.irrmann@motola.com

5.0 Further Assistance From Motorola

You can also contact the Customer Help Desk through the following web address.
<http://www.motorola.com/governmentandenterprise/contactus>

Glossary

This glossary contains an alphabetical listing of terms and their definitions that are applicable to portable and mobile subscriber radio products. All terms do not necessarily apply to all radios, and some terms are merely generic in nature.

Term	Definition
Analog	Refers to a continuously variable signal or a circuit or device designed to handle such signals.
Band	Frequencies allowed for a specific purpose.
CPS	Customer Programming Software: Software with a graphical user interface containing the feature set of a radio.
Default	A pre-defined set of parameters.
Digital	Refers to data that is stored or transmitted as a sequence of discrete symbols from a finite set; most commonly this means binary data represented using electronic or electromagnetic signals.
DPL	Digital Private-Line: A type of digital communications that utilizes privacy call, as well as memory channel and busy channel lock out to enhance communication efficiency.
FCC	Federal Communications Commission.
Frequency	Number of times a complete electromagnetic-wave cycle occurs in a fixed unit of time (usually one second).
GPIO	General-Purpose Input/Output.
IC	Integrated Circuit: An assembly of interconnected components on a small semiconductor chip, usually made of silicon. One chip can contain millions of microscopic components and perform many functions.
IF	Intermediate Frequency.
kHz	kilohertz: One thousand cycles per second. Used especially as a radio-frequency unit.
LCD	Liquid-Crystal Display: An LCD uses two sheets of polarizing material with a liquid-crystal solution between them. An electric current passed through the liquid causes the crystals to align so that light cannot pass through them.
LED	Light Emitting Diode: An electronic device that lights up when electricity is passed through it.
MDC	Motorola Digital Communications.
MHz	Megahertz: One million cycles per second. Used especially as a radio-frequency unit.
Paging	One-way communication that alerts the receiver to retrieve a message.

Term	Definition
PC Board	Printed Circuit Board. Also referred to as a PCB.
PL	Private-Line Tone Squelch: A continuous sub-audible tone that is transmitted along with the carrier.
Programming Cable	A cable that allows the CPS to communicate directly with the radio using RS232.
Receiver	Electronic device that amplifies RF signals. A receiver separates the audio signal from the RF carrier, amplifies it, and converts it back to the original sound waves.
Repeater	Remote transmit/receive facility that re-transmits received signals in order to improve communications range and coverage (conventional operation).
RF	Radio Frequency: The portion of the electromagnetic spectrum between audio sound and infrared light (approximately 10 kHz to 10 GHz).
RX	Receive.
Signal	An electrically transmitted electromagnetic wave.
Spectrum	Frequency range within which radiation has specific characteristics.
Squelch	Muting of audio circuits when received signal levels fall below a pre-determined value. With carrier squelch, all channel activity that exceeds the radio's preset squelch level can be heard.
TOT	Time-out Timer: A timer that limits the length of a transmission.
TPL	Tone Private Line
Transceiver	Transmitter-receiver. A device that both transmits and receives analog or digital signals. Also abbreviated as XCVR.
Transmitter	Electronic equipment that generates and amplifies an RF carrier signal, modulates the signal, and then radiates it into space.
TX	Transmit.
UHF	Ultra-High Frequency.
USB	Universal Serial Bus: An external bus standard that supports data transfer rates of 12 Mbps.
VIP	Vehicle Interface Port.



MOTOROLA

Recommended Dealer:
www.hkrsolutions.com

HKRSolutions
Two-way Radio & Accessories Specialist

MOTOROLA and the Stylized M Logo are registered in the U.S. Patent and Trademark Office. All other product or service names are the property of their respective owners.

© 2007 Motorola, Inc.
All rights reserved. March 2007.

www.motorola.com/mototrbo



6866576D03-A